

REVISIONS			
REV	DESCRIPTION	DATE	APPROVED
2	WAS CUSTOM TOOL	02/04/11	VAW

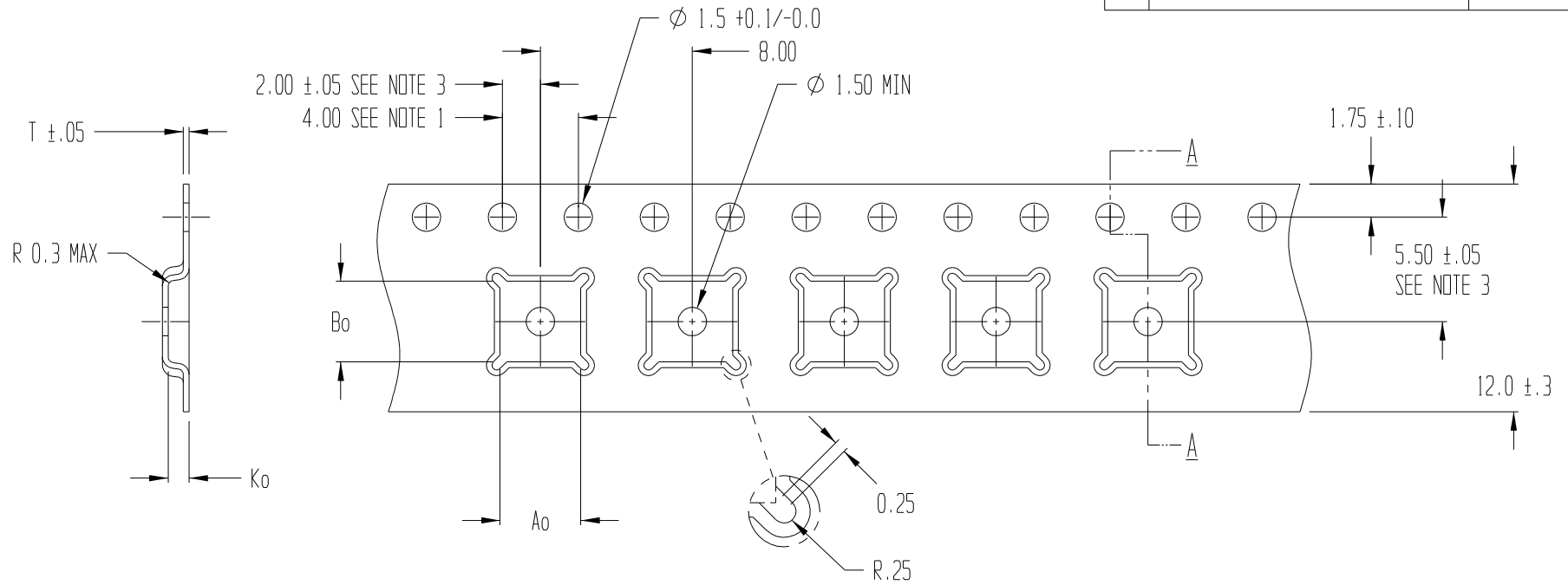

SECTION A - A

$A_0 = 4.25$
 $B_0 = 4.25$
 $K_0 = 1.10$

PART#	T	MATERIAL	DRAWING NO.
ML0404-CC	0.30	PS+C	T103023BT
ML0404-CI	0.25	PS+C	T103023BT
ML0404-CD	0.30	PS+C	T103023BT

NOTES:

- 10 SPROCKET HOLE PITCH CUMULATIVE TOLERANCE ± 0.2
- POCKET POSITION RELATIVE TO SPROCKET HOLE MEASURED AS TRUE POSITION OF POCKET, NOT POCKET HOLE
- A_0 AND B_0 ARE CALCULATED ON A PLANE AT A DISTANCE "R" ABOVE THE BOTTOM OF THE POCKET.



TITLE ADVANTEK PART DRAWING NUMBER ML0404-C CARRIER TAPE			
TOLERANCES - UNLESS NOTED 1PL ± 0.2 2PL ± 0.10		MATERIAL PS+C	
		ALL DIMENSIONS IN MILLIMETERS	DWG SIZE B
DRAWN BY TMD/BTH	DATE 8/23/00	SCALE 4:1	SHEET 1 OF 1
REFERENCE NO. T-10364 / 7471.00	DWG NO. SEE TABLE	REV 2	