

REVS				
REV.	DESCRIPTION	DATE	GS#	APPROVED
1	DEPTH CHANGE	8/1/89		BJO
2	DEPTH CHANGE	8/1/89		BJO
3	DEPTH CHANGE	8/1/89		BJO
4	REMOVED B, C, D TO CLOSED TOOLING	3/13/92		CKS
5	DRAWING FORMAT CHANGE	8/31/01		TMO
6	REINSTATE ORIG. DATE DRAWN BY	2/11/02		BTH
7	ADDED MATERIAL TABLE, DRAWING FORMAT CHANGE	1/19/23	78366	MME

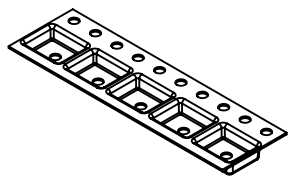
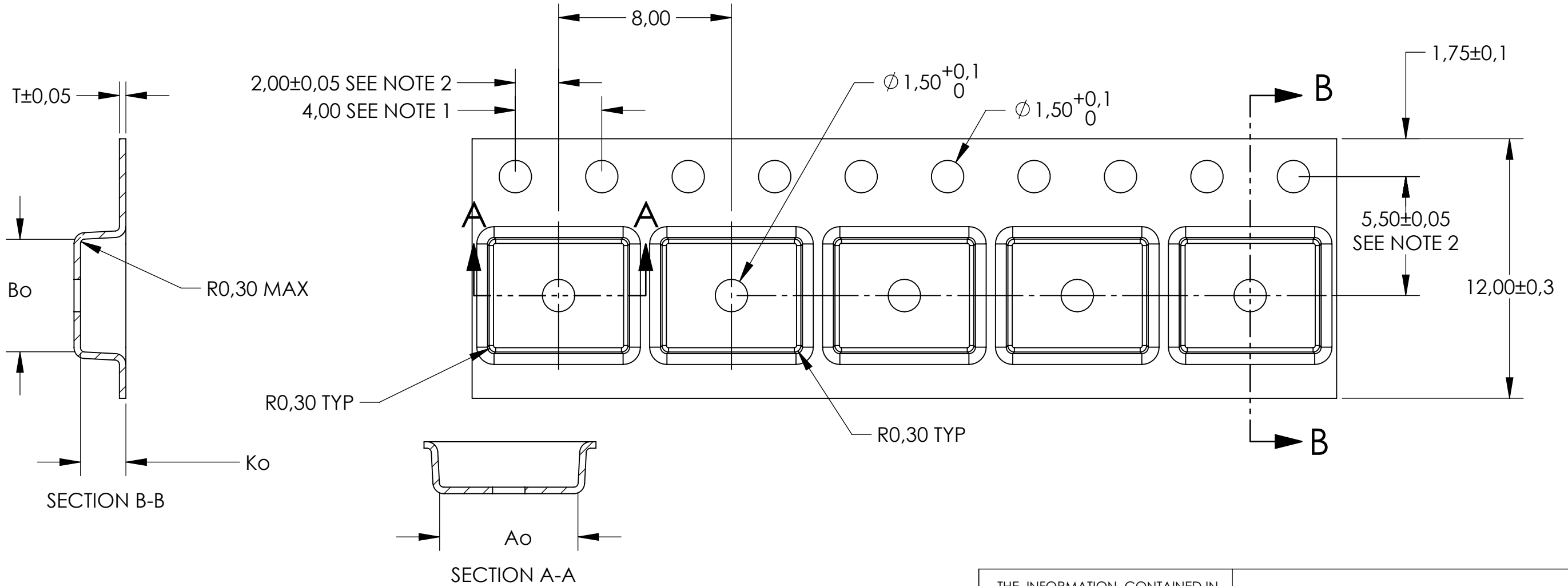

SCALE 1:1

PART #	T	MATERIAL	DRAWING #
SOIC08-AC	0,30	PS+C	A0203-89-12(6)
SOIC08-AD	0,30	PS+C	T108760BT
SOIC08-ABB	0,25	PC	T108761BT
SOIC08-AKC	0,30	PS+C	T121324BT

	DIM	±
Ao	6,40	0.1
Bo	5,20	0.1
Ko	2,10	0.1

- NOTES:
- 10 SPROCKET HOLE PITCH CUMULATIVE TOLERANCE  $\pm 0.2$
  - POCKET POSITION RELATIVE TO SPROCKET HOLE MEASURED AS TRUE POSITION OF POCKET, NOT POCKET HOLE.
  - Ao AND Bo ARE MEASURED ON A PLANE AT A DISTANCE "R" ABOVE THE BOTTOM OF THE POCKET.

THE INFORMATION CONTAINED IN THIS DRAWING IS THE SOLE PROPERTY OF ADVANTEK INC. ANY REPRODUCTION IN PART OR WHOLE WITHOUT THE WRITTEN PERMISSION OF ADVANTEK INC. IS PROHIBITED.



TITLE: ADVANTEK PART DRAWING NUMBER SOIC08-A  
CARRIER TAPE

ALL DIMS IN MILLIMETERS PER ASME Y14.5M TOLERANCES UNLESS - SPECIFIED 1 PL $\pm 0.2$ 2 PL $\pm 0.10$	MATERIAL <b>SEE TABLE</b>	APPROVED BY:	
CAD GENERATED DRAWING, DO NOT MANUALLY UPDATE DO NOT SCALE DRAWING	DRAWN BY: <b>CKS/SOC</b>	DATE <b>1/3/89</b>	SCALE: <b>5:1</b>
	PROJECT #	SHEET <b>1 OF 1</b>	SIZE <b>B</b>
		DRAWING # <b>SEE TABLE</b>	REV. <b>7</b>