



## GMX-W1 Ultrasonic Wire Splicer

Emerson's Branson GMX-W1 joins wires reliably and quickly while providing maximum flexibility. GMX-W1 is an ergonomic wire splicing system that can splice wires in-line, or in a pig-tail configuration. Lightweight and compact design, GMX-W1 is ideal for use as a portable unit on wire harness in-line assembly boards.

### KEY FEATURES:

- **22" capacitive touchscreen** for fast response time
- **User-friendly HMI**
  - User-friendly intuitive interface
  - Optimized production capability for splicing, sequencing and harness boards
  - Multiple user level and access management
  - Traceability for statistical evaluation and log file
- **Ergonomic design** - allows ease of use and flexibility for different applications
- **LED color status indicator** for real time monitoring of machine status and splice quality
- **Illuminated weld area** facilitates part loading

### OTHER FEATURES:

- **Automatic calibration** allows quick, easy self-calibration on start-up
- **Network connectivity**
  - Interface to MES (Manufacturing Execution System) directly or via third party suppliers
  - KSK network compatibility
  - Interfaces with shrink tube equipment (Raychem) for data exchange and control
- **CE and FCC certifications** - Worldwide conformity

**OPTIONS:**

- In-line wire cutting module
- Bar code scanner
- Work table
- Cradle for in-line splicing

**Applications and Industries\***

Ultrasonic wire splicing technology is widely used in the automotive, machinery, recreation, home appliance, and other industries where reliable and efficient electrical connections are required. Splicing ultrasonically results in a superior electrical metalurgical bond over crimping, soldering or resistance welding. Ultrasonics offer savings in power consumption, elimination of consumables, and longer tool life. Typical applications are splicing and solidification of the ends of stranded copper wires.

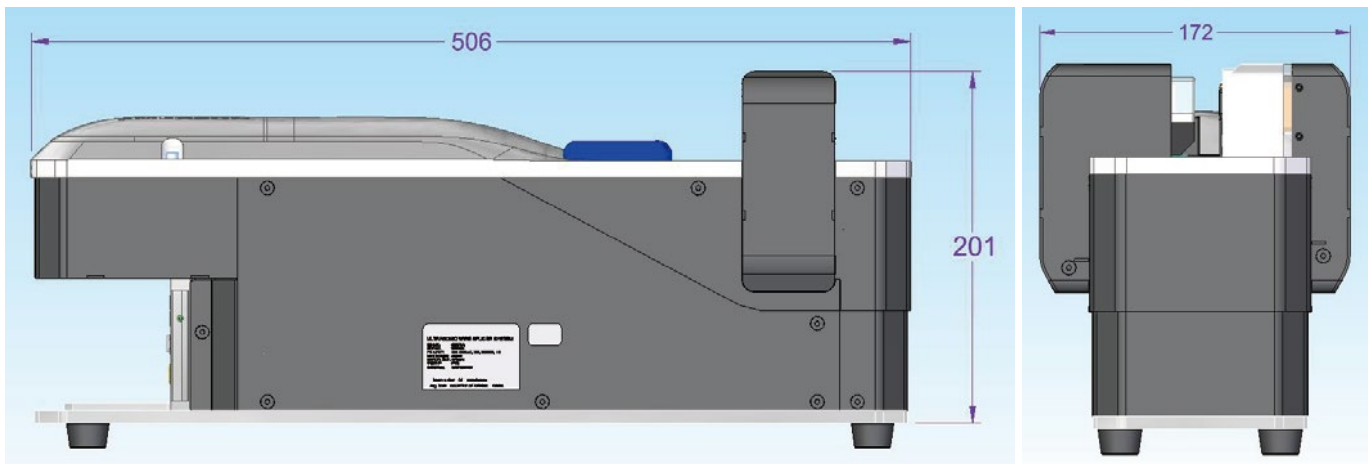
**Dimensions****SPECIFICATIONS**

Frequency	20kHz
Output power	4,000 W
Power supply	200~230V, single phase, 25A max
Pneumatic	5.5 bar (80psi) clean, dry air
Cross section	1.05~40mm <sup>2</sup>
Actuator weight	22kg

Notes: Cross sections outside of this operating window may be possible, please contact Branson for consultation.

\*This product is designed for copper wire splicing applications. Although other materials may be possible, customers are responsible for testing and qualifying additional materials.

**Americas**

Branson Ultrasonics Corp.  
41 Eagle Road  
Danbury, CT 06813-1961  
T: 203-796-0400  
F: 203-796-9838  
[www.Emerson.com/Branson](http://www.Emerson.com/Branson)

**Europe**

Branson Ultraschall  
Niederlassung der Emerson  
Technologies GmbH & Co. OHG  
Waldstrasse 53-55  
63128 Dietzenbach, Germany  
T: +49-6074-497-0  
F: +49-6074-497-199  
[www.Emerson.com/Branson](http://www.Emerson.com/Branson)

**Asia**

Branson Ultrasonics (Shanghai) Co., Ltd.  
758 Rong Le Dong Road  
Song Jiang, Shanghai, PRC, 201613  
T: 86-21-3781-0588  
F: 86-21-5774-5100  
[www.Emerson.com/Branson](http://www.Emerson.com/Branson)