

e-flex  
**smt**  
microsystems

**Board Handling**

Electronic Manufacturing Equipment

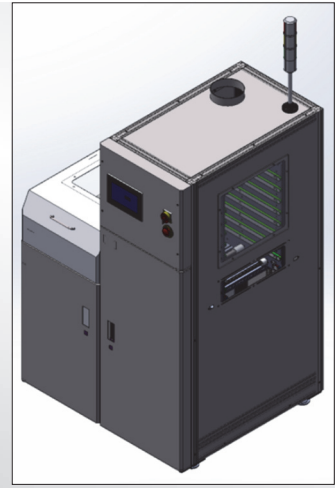
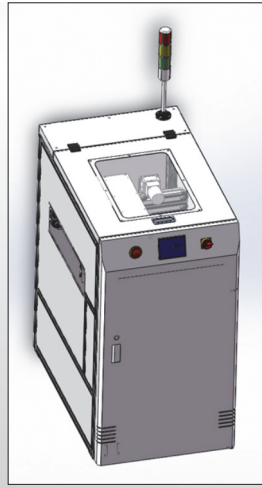
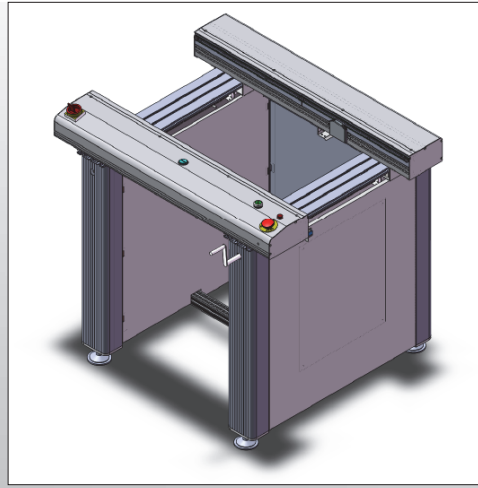
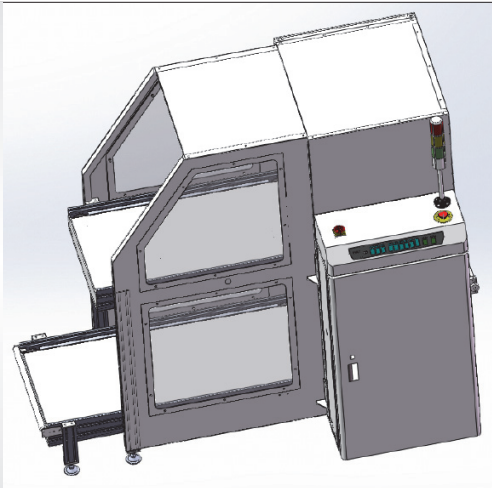

**LOADERS/UNLOADERS**

**CONVEYORS**

**INVERTERS**

**BUFFERS**

**PLUS MANY OTHERS...**

[www.eflexsmt.com](http://www.eflexsmt.com)



**Enterprise Mission**

**Enterprise Core Values**

**Business Management Concept**

**Quality Management Concept**

## Contents

About us	01/02
Inspection Conveyor (Economic)	03
Dual Rail Conveyor (Hybrid)	04
Inspection Conveyor (High-End)	05
Dual Rail Conveyor	06
Reject Conveyor	07
Flash Conveyor	08
Manual Lifting Gate Conveyor	09
Lowering Gate Conveyor	10
Shuttle Conveyor	11
Telescopic Gate Conveyor	12
Multi-Function Magazine Buffer	13
Multi-Function Vertical Buffer	14
LIFO Vertical Buffer	15
NG/OK Vertical Buffer	16
Heavy-Duty Buffer	17
Curing Buffer	18
Turn Conveyor	19
PCB Inverter	20
Vacuum Bear Board Loader	21
Destacker/ Push-up Stacker	22
Vacuum Loader for LED Lights	23
Unloader for LED Lights	24
Multi Magazine Loader/Unloader	25
Mini Magazine Loader/Unloader	26
90 Degree Unloader	27
Signal Magazine Unloader	28
NG/OK Unloader/Dual Magazine Unloader	29
Elevator Conveyor	30
Insertion Conveyor	31
Flat Belt Conveyor	32
PCB Cleaning Machine	33
Wave Outfeed Conveyor	34
Automation line examples	35
Customers world wide	36
Quality assurance & Agent network	37
After-sales service	38

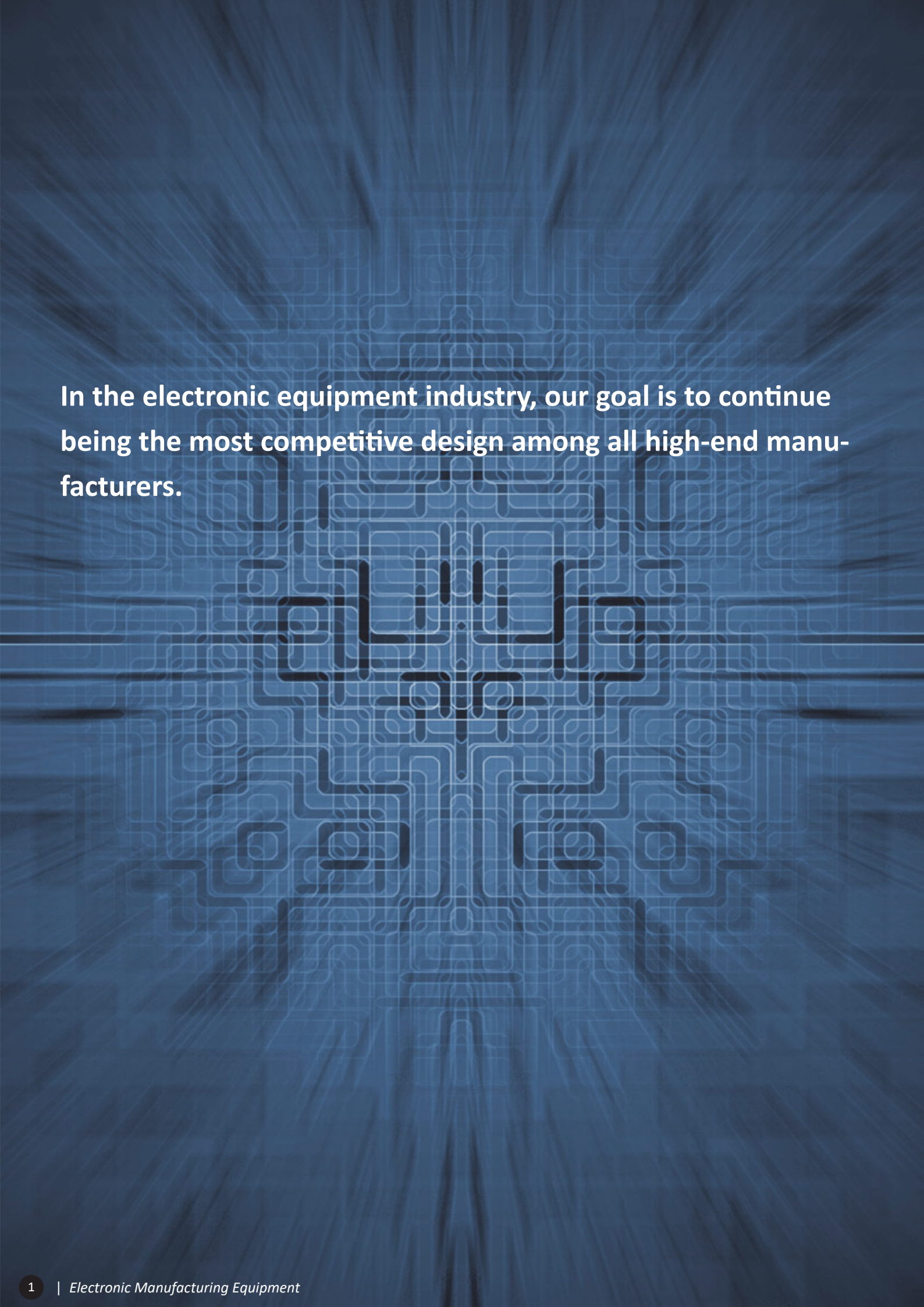

**In the electronic equipment industry, our goal is to continue being the most competitive design among all high-end manufacturers.**

## About Us



e-Flex SMT Microsystems supplies a wide range of the most innovative and reliable types of SMT (Surface Mount Technology) equipment and Electronic devices manufactured in East Asia.

Our goal is to expand day by day into each country and to bring satisfaction to our customers, offering solutions at a cost-effective rate. We are constantly developing and improving our existing models of machinery in order to be up to date to the current levels of sophistication.

Our full line of equipment and accessories is actually fitting every demand of our customer's SMT lines. We bring solutions to every need at a very reasonable cost.

Located in Hong Kong, Asia's World City and home of the Electronics industry in Asia, e-Flex SMT Microsystems services world-wide and has already many distributors in different countries.

We are experts in selecting the best choices of equipment and machinery under the demands of our clients.

With a combination of cost-effective rates and machinery expertise, e-Flex SMT Microsystems is the best choice you might have at the present moment as your SMT supplier.

# ■ Inspection Conveyor (Economic Type)

## Features

- Modular design, PLC controlled
- Stability enhanced by heavy design
- Worktable included by default
- Smooth and parallel width adjustment (stainless steel screws)
- Different lengths available upon request
- Multi-segment concept available upon request
- Automatic/Manual modes
- Variable speed control
- Inspection button
- SMEMA compatible
- Conveyor height  $950 \pm 30\text{mm}$

## Options

- ESD Covers anti-dust
- Touch screen
- High-Clearance on request
- Cooling fans on top/bottom for after-reflow
- Light system for better inspection
- Support for Monitor
- Shelf with ESD component boxes
- Motorized/Automatic width adjustment
- Choice of different belt width and chain transport system
- Mechanical stopper
- Foot pedal pass control
- Narrow footprint
- With bottom cabinet



## Technical Parameters

Description	This unit is used as a visual inspection station for operators between SMT machines or board handling unit to link the machines.
Belt Type	Antistatic Flat Belt of 3mm width
Conveyor Speed	0.5-20m/min or specify
Power Source	AC 220V, 50/60Hz, 1 phase
Power Consumption	100W MAX

## Schematic

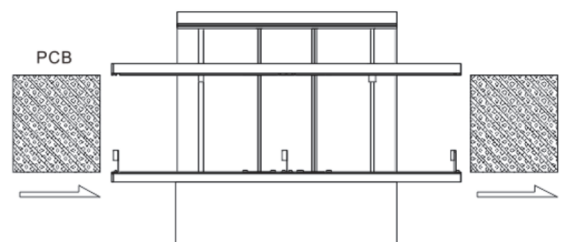

## Specification

Size	Model	Machine Dimensions(LxWxH) in mm	Effective PCB Size (LxW) in mm	Weight (Kg)
L	WH-C050SD3BL	500x695x1170	50x50 - 445x330	87
XL	WH-C050SD3BXL	500x755x1170	50x50 - 445x460	92
L	WH-C100SD3BL	1000x695x920	50x50 - 530x330	92
XL	WH-C100SD3BXL	1000x755x920	50x50 - 530x460	97

# ■ Inspection Conveyor (Hybrid Type)

## Features

- Modular design, PLC controlled
- Stability enhanced by heavy design
- High-end rails on top of an economic type structure
- Smooth and parallel width adjustment (stainless steel screws)
- Different lengths available upon request
- Multi-segment concept available upon request
- Automatic/Manual modes
- Variable speed control
- Inspection button
- SMEMA compatible
- Conveyor height  $950 \pm 30\text{mm}$



## Options

- ESD Covers anti-dust
- Touch screen
- High-Clearance on request
- Cooling fans on top/bottom for after-reflow
- Light system for better inspection
- Support for Monitor
- Shelf with ESD component boxes
- Motorized/Automatic width adjustment
- Choice of different belt width and chain transport system
- Mechanical stopper
- Foot pedal pass control
- Narrow footprint
- Safety interlocker for the covers

## Technical Parameters

Description	This unit is used as a visual inspection station for operators between SMT machines or board handling unit to link the machines.
Belt Type	Antistatic Flat Belt of 3mm width
Conveyor Speed	0.5-20m/min or specify
Power Source	AC 220V, 50/60Hz, 1 phase
Power Consumption	100W Max.

## Schematic

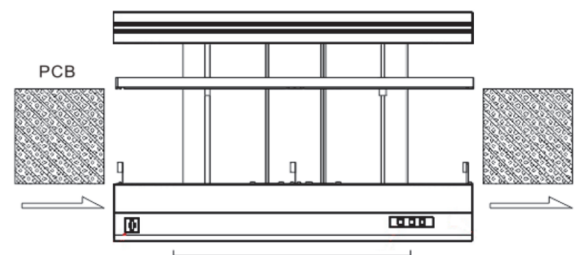

## Specification

Units in mm

Size	Model	Machine Dimensions(LxWxH) in mm	Effective PCB Size (LxW) in mm	Weight (Kg)
L	WH-C050ZD3BL	500x695x1170	50x50 - 445X330	87
XL	WH-C050ZD3BXL	500x755x1170	50x50 - 445X460	92
L	WH-C100ZD3BL	1000x695x920	50x50 - 530X330	92
XL	WH-C100ZD3BXL	1000x755x920	50x50 - 530x460	97

# Inspection Conveyor (High-End Type)

## Features

- Modular design, PLC controlled
- Stability enhanced by heavy design
- Beautiful design with aluminum finishing
- Smooth and parallel width adjustment (stainless steel screws)
- Different lengths available upon request
- Multi-segment concept available upon request
- Automatic/Manual modes
- Variable speed control
- Inspection button
- SMEMA compatible
- Conveyor height  $950 \pm 30$ mm

## Options

- ESD Covers anti-dust
- Touch screen
- High-Clearance on request
- Cooling fans on top/bottom for after-reflow
- Light system for better inspection
- Support for Monitor
- Shelf with ESD component boxes
- Motorized/Automatic width adjustment
- Choice of different belt width and chain transport system
- Mechanical stopper
- Foot pedal pass control
- Narrow footprint
- Safety interlocker for the covers



## Technical Parameters

Description	This unit is used as a visual inspection station for operators between SMT machines or board handling unit to link the machines.
Belt Type	Antistatic Flat Belt of 3mm width
Conveyor Speed	0.5-20m/min or specify
Power Source	AC 220V, 50/60Hz, 1 phase
Power Consumption	100W Max.

## Schematic

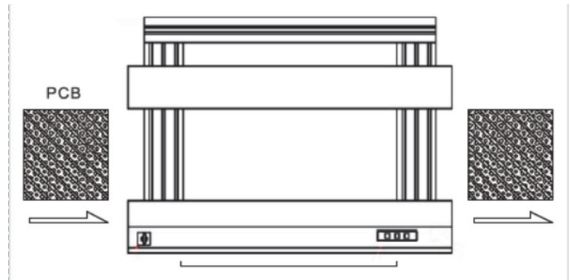

## Specification

Size	Model	Machine Dimensions(LxWxH) in mm	Effective PCB Size (LxW) in mm	Weight (Kg)
L	WH-C050HD3BL	500x780x1170	50x50 - 445X400	87
XL	WH-C050HD3BXL	500x849x1170	50x50 - 445X460	92
L	WH-C100HD3BL	1000x790x920	50x50 - 530X400	92
XL	WH-C100HD3BXL	1000x849x920	50x50 - 530x460	97



# Dual Rail Conveyor



## Features

- Modular design, PLC controlled
- Stability enhanced by heavy design
- Worktable included by default
- Smooth and parallel width adjustment (stainless steel screws)
- Different lengths available upon request
- Multi-segment concept available upon request
- Automatic/Manual modes
- Independent variable speed controls for each rail
- Independent inspection buttons
- SMEMA compatible
- Conveyor height  $950 \pm 30\text{mm}$

## Options

- ESD Covers anti-dust
- Touch screen
- High-Clearance on request
- Cooling fans on top/bottom for after-reflow
- Light system for better inspection
- Support for Monitor
- Shelf with ESD component boxes
- Motorized/Automatic width adjustment
- Choice of different belt width and chain transport system
- Mechanical stopper
- Foot pedal pass control
- Narrow footprint
- With bottom cabinet

## Technical Parameters

Description	This unit is used as a visual inspection station for operators between SMT machines or board handling unit to link the machines. Dual rail version.
Belt Type	Antistatic Flat Belt of 3mm width
Conveyor Speed	0.5-20m/min or specify
Power Source	AC 220V, 50/60Hz, 1 phase
Power Consumption	100W Max.

## Schematic

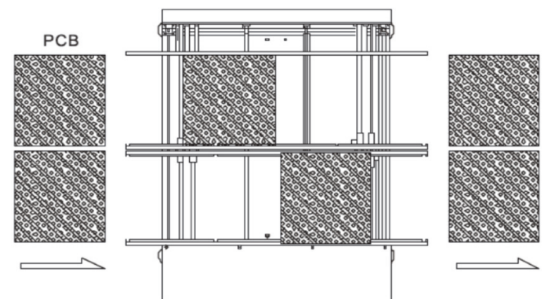

## Specification

Size	Model	Machine Dimensions(LxWxH) in mm	Effective PCB Size (LxW) in mm	Weight (Kg)
XL	WH-C050SD3BXL-Y	500x1005x920	50x50 - 530x460	97
XL	WH-C100SD3BXL-Y	1000x1005x950	50x50 - 530x460	107

# Reject Conveyor

## Features

- Modular design, PLC controlled
- Stability enhanced by heavy design
- Beautiful design with aluminum finishings
- Smooth and parallel width adjustment (stainless steel screws)
- Different lengths available upon request
- Touch screen control
- Stacks up to 2 NG boards
- Multi-segment concept available upon request
- Automatic/Manual modes
- Reject, inspect and pass-through modes
- Variable speed control
- SMEMA compatible
- Conveyor height 950±30mm



## Options

- High-clearance on request
- Ergonomic design arm rest on the front
- Motorized/Automatic width adjustment
- Multiple belt width and chain transport system available
- 5 NG boards capacity
- Signal tower for warning when the platform is full



Touch Screen Control

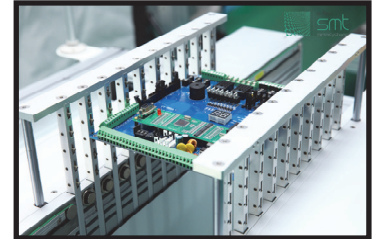

Lifting Platform

## Technical Parameters

Description	This unit allows Good and NG board separation in a production line. It can be used when visual inspection of PCB's is required. PCB's will continue to run, thus without interrupting the PCB flow
Belt Type	Antistatic Flat Belt of 3mm width
Conveyor Speed	0.5-20m/min or specify
Power Source	AC 220V, 50/60Hz, 1 phase
Power Consumption	100 Max
Air Pressure & Consume	4-6 bar, 10 l/min Max.

## Schematic

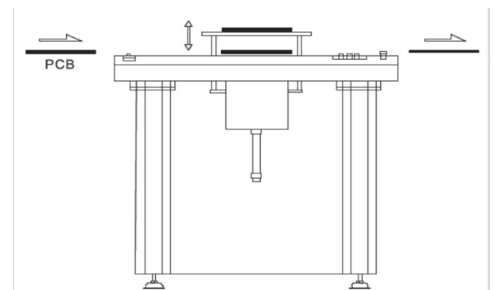

## Specification

Size	Model	Machine Dimensions(LxWxH) in mm	Effective PCB Size (LxW) in mm	Weight (Kg)
L	WH-C100HD3BL-R2	1000x830x950	50x50 - 530x400	142
XL	WH-C100HD3BXL-R2	1000x890x950	50x50 - 530x460	147

## Flash-Off Conveyor

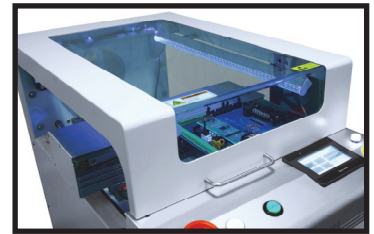

UV Inspection



Exhaust sensor

### Features

- Modular design, PLC controlled
- Smooth and parallel width adjustment (stainless steel screws)
- Covers which protect the boards against dust
- Segments with independent flash-off time (programmable)
- Automatic/Manual modes with inspection button
- Independent variable speed controls for each rail
- SMEMA compatible
- Conveyor height  $950 \pm 30$ mm
- Extractable tray for easy clean-up of coating droplets
- Full control and settings by touch screen
- Exhaust sensor which forces to use air extraction

### Options

- UV lights to analyze the coating result over the boards
- Automatic width adjustment
- Safety interlocker for covers
- 3 color signal tower
- Choice of different belt width and chain transport system
- Foot pedal
- Mechanical stopper

### Technical Parameters

Description	This unit is used as a visual inspection station for operators controlling the boards right after a conformal coating line.
Belt Type	Antistatic Flat Belt of 12mm width
Conveyor Speed	0.5-20m/min or specify
Power Source	AC 220V, 50/60Hz, 1 phase
Power Consumption	100 W

### Schematic

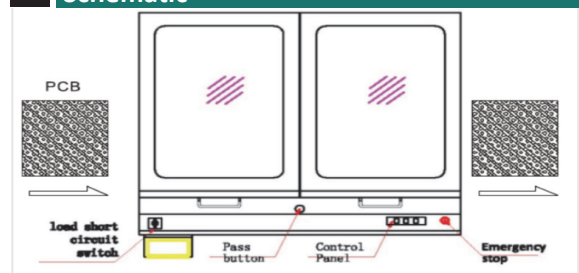

### Specification

Units in mm

Size	Model	Machine Dimensions(LxWxH) in mm	Effective PCB Size (LxW) in mm	Weight (Kg)
L	WH-C50HD12TL-CALOUVT	500X953X1170	50x50 - 445x400	80
XL	WH-C50HD12TXL-CALOUVT	500X1013X1170	50x50 - 445x460	110
L	WH-E100HD12TL-CALOUVT	1000x930x950	50x50—530x400	120
XL	WH-E100HD12TXL-CALOUVT	1000x990x950	50x50 - 530X460	150

# Manual Lifting Gate Conveyor

## Features

- Lowering & lifting of the gate conveyor is done manually
- Safety sensor installed to enhance safety
- 650mm passage way, or specify

## Options

- High-end rail
- ESD Covers anti-dust
- Touch screen
- High-Clearance on request
- Motorized/Automatic width adjustment
- Choice of different belt width and chain transport system



## Technical Parameters

Description	This unit is used to allow passage across the line when required.
Belt Type	Antistatic Flat Belt of 3mm width
Conveyor Speed	0.5-20m/min or specify
Power Source	AC 220V, 50/60Hz, 1 phase
Power Consumption	100 Max
Cycle time	Approx. 6 Seconds

## Schematic

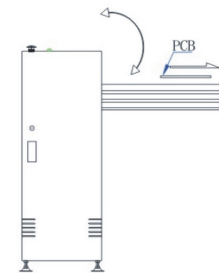

## Specification

Size	Model	Machine Dimensions(LxWxH) in mm	Effective PCB Size (LxW) in mm	Weight (Kg)
M	WHM-021SD3BM	1000X720X1210	50X50-330X250	140
L	WHM-021SD3BL	1000X800X1310	50X50-445X330	160
XL	WHM-021SD3BXL	1000x980x1310	50x50 - 530x460	280

## Lowering Gate Conveyor



### Features

- Lowering & lifting of the gate conveyor is done by push buttons
- Safety sensor installed to enhance safety
- 650mm passage way, or specify
- Variable speed control
- Conveyor height  $950 \pm 30$ mm
- SMEMA compatible

### Options

- High-end rail
- ESD Covers anti-dust
- Touch screen
- High-Clearance on request
- Motorized/Automatic width adjustment
- Choice of different belt width and chain transport system

### Technical Parameters

Description	This unit is used to allow passage across the line when required.
Belt Type	Antistatic Flat Belt of 3mm width
Conveyor Speed	0.5-20m/min or specify
Power Source	AC 220V, 50/60Hz, 1 phase
Power Consumption	100 Max
Air Pressure & Consume	4-6 bar, 48 l/min Max.

### Schematic

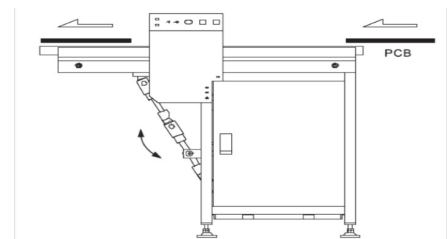

### Specification

Units in mm

Size	Model	Machine Dimensions(LxWxH) in mm	Effective PCB Size (LxW) in mm	Weight (Kg)
M	WHM-022SD3BM	1300X560X1250	50X50-330X250	160
L	WHM-022SD3BL	1300X720X1250	50X50-445X330	180
XL	WHM-022SD3BXL	1300x800x1250	50x50 - 530x460	200

# Shuttle Conveyor

## Features

- Simple touch screen control panel
- Enclosed design ensures high level of safety
- Swift, smooth and precise operation
- Auto-width adjustment
- Different lengths available upon request
- Different working ways upon request
- SMEMA compatible
- Conveyor height  $950 \pm 30\text{mm}$

## Options

- High-Clearance on request
- Choice of different belt width and chain transport system



## Technical Parameters

Description	This unit is used to redirect the PCB's flow into different channels in a production line.
Belt Type	Antistatic Flat Belt of 3mm width
Cycle Time	Depending on traversing distance
Power Source	AC 220V, 50/60Hz, 1 phase
Power Consumption	250 Max

## Schematic

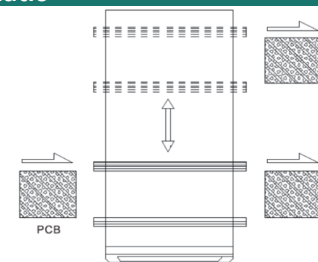

## Specification

Size	Model	Machine Dimensions (LxWxH) in mm	Effective PCB Size (LxW) in mm	Weight (Kg)	Machine Width
M	WHM-22010SD3TM	503x1050x950	50x50 - 330x280	140	Depends on traversing distance
L	WHM-22013SD3TL	503x1350x950	50x50 - 445x390	200	Depends on traversing distance
XL	WHM-22013SD3TXL	503x1550x950	50x50-530x460	260	Depends on traversing distance

## Telescopic Gate Conveyor



### Features

- User friendly soft touch LED membrane control panel
- Swift and smooth retraction/extension of the conveyor
- Safety sensor installed to enhance safety
- 850mm passage way, or specify
- Conveyor height  $950 \pm 30$ mm
- SMEMA compatible

### Options

- High-end rail
- High-Clearance on request
- Motorized/Automatic width adjustment
- Choice of different belt width and chain transport system



Open Gate

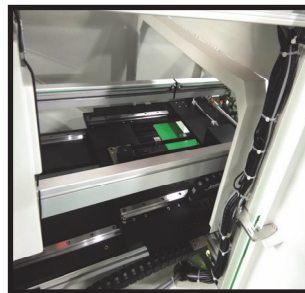

Internal lifter (NC)

### Technical Parameters

Description	This unit is used to allow passage across the line when required.
Belt Type	Antistatic Flat Belt of 3mm width
Cycle Time	Approx. 12 seconds
Power Source	AC 220V, 50/60Hz, 1 phase
Power Consumption	300 Max
Air Pressure & Consume	4-6 bar, 16 l/min Max.

### Schematic

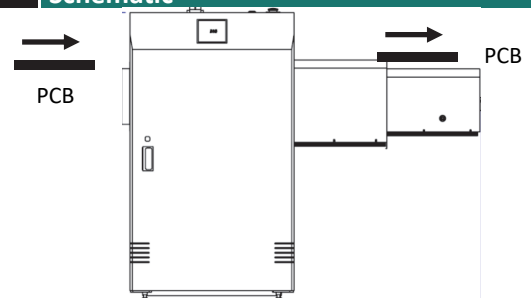

### Specification

Units in mm

Size	Model	Machine Dimensions (LxWxH) in mm	Effective PCB Size (LxW) in mm	Weight (Kg)
L	WHM-023SD3BL	1500x848x1300	50x50 - 445x330	250
XL	WHM-023SD3BXL	1500x950x1300	50x50- 530x460	300
L	WHM-027SD3BL	1550x850x1300	50x50 - 445x330	250
XL	WHM-027SD3BXL	1550x950x1300	50x50- 530x460	300

# Multi-Function Magazine Buffer

## Features

- User friendly touch screen control
- Top & bottom pneumatic clamps to secure magazine rack
- Pressure regulated pusher to prevent board damage
- Fast, smooth and precise indexing
- Available modes: Pass-through, Loader, Unloader, NG, LIFO.
- Conveyor height 950±30mm
- SMEMA compatible

## Option

- Additional magazines buffering capacity available upon request
- Automatic width adjustment
- Cooling fans
- Safety interlockers
- Universal type (Multiple magazine sizes)



Double cylinder



## Technical Parameters

Description	This unit is actually used as a combination of loader/unloader/magazine rack buffer.
Capacity	Up: 1 rack; Down: 2 racks
Cycle Time	Approx. 20 seconds
Indexing Pitch	10, 20, 30, 40mm or specify
Power Source	AC 220V, 50/60Hz, 1 phase
Power Consumption	300W Max.
Air Pressure & Consume	4-6 bar, 15 l/min Max.

## Schematic

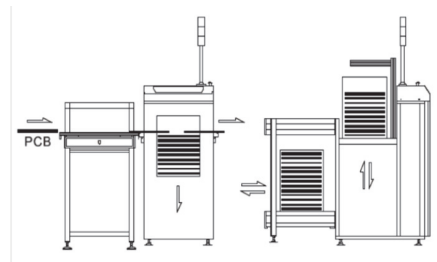

## Specification

Size	Model	Machine Dimensions (LxWxH) in mm	Effective PCB Size (LxW) in mm	Rack Size (LxWxH)	Weight (Kg)
M	WHM-101HD3TL-C	1043X1642X1205	50x100 - 330x250	355x320x563	180
L	WHM-101HD3TL-C	1123x1957x1205	50x100 - 445x330	460x400x563	200
LL	WHM-101HD3TLL-C	1435X2182X1205	50x100 - 530x390	535x460x570	220
XL	WHM-101HD3TXL-C	1505X2182X1205	50x100 - 530x460	535x530x570	240



# Multi-Function Vertical Buffer



## Features

- User friendly touch screen control panel
- FIFO, LIFO and pass-through operating modes selectable
- Fast, smooth and precise indexing (Freq. inverter controller)
- Selectable system threshold
- Smooth and parallel width adjustment (lead screw)
- Conveyor height  $950 \pm 30$ mm
- SMEMA compatible
- Up to 25 slots for PCB storage
- Coating Lines model available, with 8 slot capacity and high clearance for storing heavy pallets

## Options

- Side conveyor
- Automatic width adjustment
- Safety interlockers
- UV light
- Chain system instead of belt
- Flash-off timer and exhaust sensor

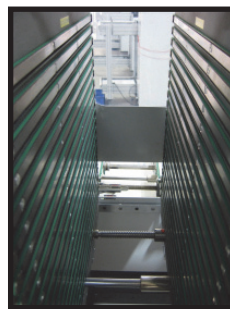

Internal belts

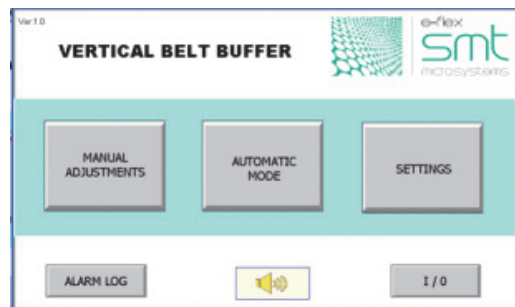

## Technical Parameters

Description	This unit is used as a buffer between SMT machines
Cycle Time	Approx. 10 seconds
Max. PCB Capacity	25 pcs maximum
Internal belts Type	Antistatic Flat Belt of 3mm width
Indexing Pitch	10, 20mm or specify
Power Source	AC 220V, 50/60Hz, 1 phase
Power Consumption	900W Max.
Air Pressure & Consume	4-6 bar, 15 l/min Max.

## Schematic

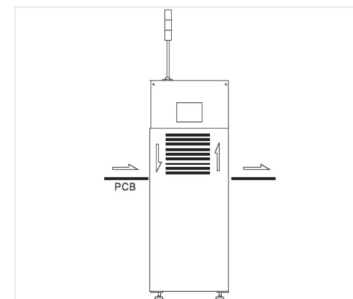

## Specification

Size	Model	Machine Dimensions (LxWxH) in mm	Effective PCB Size (LxWxH) in mm	Weight (Kg)
M	WHM-102SD3TM	505x876x1600	80x50- 330x250	380
L	WHM-102SD3TL	505x936x1600	80x50-440x350	400
XL	WHM-102SD3TXL	605x1070x1600	80x50-530x460	420

# LIFO Vertical Buffer

## Features

- User friendly soft touch LED membrane control panel
- Last In First Out (LIFO) and pass-through modes selectable
- Durable rollers as conveying transport (no belts)
- Smooth and parallel width adjustment (lead screw)
- Conveyor height  $950 \pm 30\text{mm}$
- SMEMA compatible

## Options

- Side conveyor
- Automatic width adjustment
- Safety interlockers
- UV light
- Exhaust sensor



Roller and metal support



## Technical Parameters

Description	This unit is actually used as a combination of loader/unloader/magazine rack buffer.
Capacity	Up: 1 rack; Down: 2 racks
Cycle Time	Approx. 20 seconds
Internal belts Type	10, 20, 30, 40mm or specify
Indexing Pitch	10, 20mm or specify
Power Source	AC 220V, 50/60Hz, 1 phase
Power Consumption	300W Max.
Air Pressure & Consume	4-6 bar, 15 l/min Max.

## Schematic

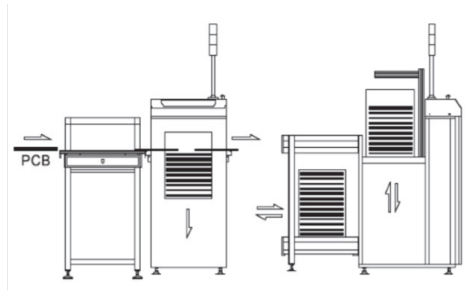

## Specification

Size	Model	Machine Dimensions (LxWxH) in mm	Effective PCB Size (LxW) in mm	Weight (Kg)
L	WHM-103HD3TL-C	505x936x1600	50x50 - 445x330	220
XL	WHM-103HD3TXL-C	605x1070x1600	50x50 - 530x460	240

## ■ NG/OK Vertical Buffer



### Features

- User friendly touch screen control panel
- Accumulates NG boards while OK boards continue
- NG boards can be taken out manually and reinserted after
- Fast, smooth and precise indexing (servo motor driven)
- Smooth and parallel width adjustment (lead screw)
- Conveyor height  $950 \pm 30$ mm
- SMEMA compatible

### Options

- Automatic width adjustment
- Safety interlockers
- Chain system instead of belt

### Technical Parameters

Description	This unit is used as a buffer to store NG and OK boards after an inspection machine (AOI/SPI), and to pass the OK boards to the next process. The NG boards will go to the upper conveyor for visual
Internal belts Type	Antistatic Flat Belt of 3mm width
Max. PCB Capacity	25 pcs maximum
Internal belts Type	10, 20, 30, 40mm or specify
Indexing Pitch	10, 20mm or specify
Power Source	AC 220V, 50/60Hz, 1 phase
Power Consumption	900W Max.
Air Pressure & Consume	4-6 bar, 15 l/min Max.

### Schematic

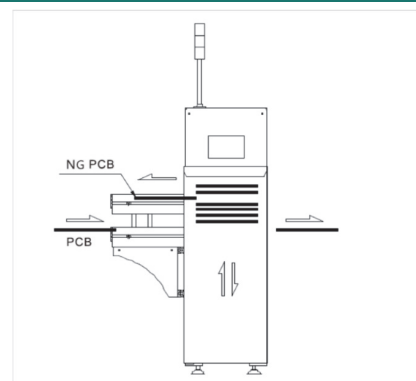

### Specification

Size	Model	Machine Dimensions (LxWxH) in mm	Effective PCB Size (LxW) in mm	Weight (Kg)
M	WHM-106SD3TM	1107x876x1600	80x50-330x250	380
L	WHM-106SD3TL	1107x936x1600	80x50-440x350	400
XL	WHM-106SD3TXL	1207x1070x1600	80x50-530x460	420

# Heavy-Duty Buffer

## Features

- User friendly touch screen control panel
- FIFO, LIFO and pass-through operating modes selectable
- Fast, smooth and precise indexing (Freq. inverter controller)
- Selectable system threshold
- Smooth and parallel width adjustment (lead screw)
- Conveyor height  $950 \pm 30$ mm
- SMEMA compatible
- Support heavy pallets
- High-clearance for boards with tall components

## Options

- Side conveyor
- UV light
- Automatic width adjustment
- Safety interlockers
- Chain system instead of belt
- Flash-off timer and exhaust sensor



8 slots for higher clearance

## Technical Parameters

Description	This unit is used as a buffer in between machines, usually for conformal coating lines
Cycle Time	Approx. 10 seconds
Max. PCB Capacity	8 pcs maximum
Internal belts Type	Antistatic Flat Belt of 8~12mm width
Indexing Pitch	10, 20mm or specify
Power Source	AC 220V, 50/60Hz, 1 phase
Power Consumption	900W Max.
Air Pressure & Consume	4-6 bar, 15 l/min Max.

## Schematic

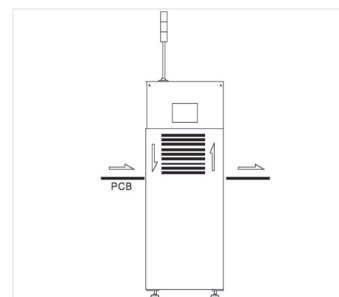

## Specification

Size	Model	Machine Dimensions (LxWxH) in mm	Effective PCB Size (LxW) in mm	Rack Size (LxWxH)	Weight (Kg)
L	WHM-108HD3TL-C	1010x870x1205	50x50 - 445x330	460x400x563	200
XL	WHM-108HD3TXL-C	1110x930x1205	50x50 - 530x460	535x530x570	240

# Curing Buffer



## Features

- User friendly touch screen control panel
- FIFO, LIFO and pass-through operating modes selectable
- Fast, smooth and precise indexing (Freq. inverter controller)
- Selectable system threshold
- Smooth and parallel width adjustment (lead screw)
- Conveyor height  $950 \pm 30$ mm
- SMEMA compatible
- Industrial heater to generate a curing chamber inside of the buffer main body
- Temperature control and monitor
- Programmable curing time
- Exhaust sensor

## Options

- UV light
- Automatic width adjustment
- Safety interlockers
- Wider belts or chain system

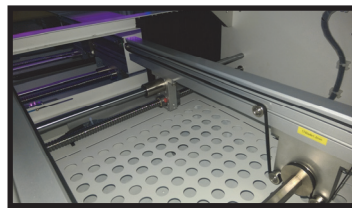

Bottom holes to distribute the heat inside the conveyor



Industrial heater to generate a curing temperature inside of the machine

## Technical Parameters

Description	This unit is used as a curing chamber in between machines, and will keep the board at a curing tempera-
Cycle Time	Approx. 10 seconds
Max. PCB Capacity	25 pcs maximum
Internal belts Type	Antistatic Flat Belt of 3 mm width
Indexing Pitch	10, 20mm or specify
Power Source	AC 220V, 50/60Hz, 1 phase
Power Consumption	900W Max.
Air Pressure & Consume	4-6 bar, 15 l/min Max.

## Schematic

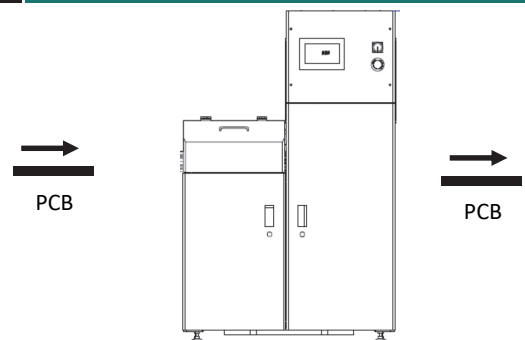

## Specification

Size	Model	Machine Dimensions (LxWxH) in mm	Effective PCB Size (LxW) in mm	Weight (Kg)
L	WHM-102SD3TL-JCOH	1256x887x1600	80X50-440X350	400
XL	WHM-102SD3TXL-JCOJH	1356x947x1600	80X50-530X460	420

# Turn Conveyor

## Features

- User friendly soft touch LED membrane control panel
- Enclosed design with built-in torque limiter to ensure a high level of safety
- Smooth and precise rotation
- Conveyor height  $950 \pm 30$ mm
- SMEMA compatible

## Options

- Motorized width adjustment
- Automatic width adjustment
- Different belt width or chain system
- Safety interlockers
- Touch screen

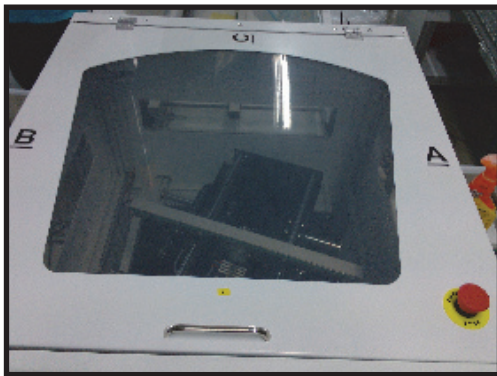

## Technical Parameters

Description	This unit is used to redirect the PCB flow in a production line (90°, 180°, 270°).
Belt Type	Antistatic Flat Belt of 3mm width
Cycle Time	Approx. 12 seconds
Power Source	AC 220V, 50/60Hz, 1 phase
Power Consumption	300 Max

## Schematic

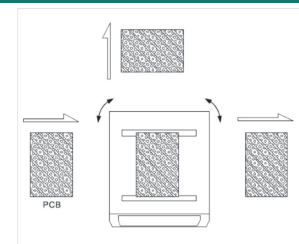

## Specification

Units in mm

Size	Model	Machine Dimensions(LxWxH) in mm	Effective PCB Size (LxH) in mm	Weight (Kg)
M	WHM-210SD3BM	500x500x1200	50x50 - 330x250	350
L	WHM-210SD3BL	580x580x1200	50x50 - 445x330	380
LL	WHM-210SD3BL	700x700x1200	50x50-530x390	395
XL	WHM-210SD3BXL	750x750x1200	50x50 - 530x460	410

# PCB Inverter



## Features

- User friendly soft touch screen
- Automatic width adjustment
- Enclosed design with built-in torque limiter to ensure a high level of safety
- Smooth and precise inverting motion
- Conveyor height  $950 \pm 30$ mm
- SMEMA compatible.
- Four different inversion modes available on demand: pass-through, normal inversion, double downstream inversion(2 types).

## Options

- Safety interlockers
- Different belt width or chain system
- Coating lines model available, with stronger modular piston and rails.

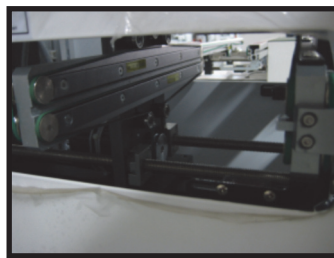

Internal belts



Heavy Duty Inverter Available on Demand

## Technical Parameters

Description	This unit is used to invert PCB's (180 °) for double side processes.
Belt Type	Antistatic Flat Belt of 3mm width
Cycle Time	Approx. 12 seconds
Power Source	AC 220V, 50/60Hz, 1 phase
Power Consumption	300 Max
Air Pressure & Consume	4-6 bar, 1.1 l/min Max.

## Schematic

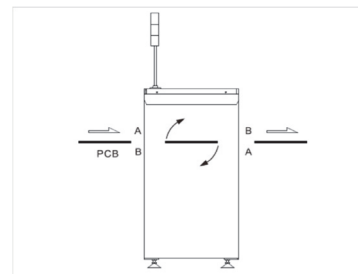

## Specification

Units in mm

Size	Model	Machine Dimensions(LxWxH) in mm	Effective PCB Size (LxH) in mm	Weight (Kg)
M	WHM-200SD3BM	504x869x1250	50x50 - 330x250	155
L	WHM-200SD3BL	554x929x1250	50x50 - 480x390	165
XL	WHM-200SD3BXL	655x1050x1250	50x50 - 530x460	175

# Vacuum Bare Board Loader

## Features

- User friendly touch screen control
- Enclosed design to ensure a high level of safety
- Adjustable vacuum stubs positions with magnets to provide a better way to hold the PCB's
- Conveyor height  $950 \pm 30$ mm
- SMEMA compatible
- Pass-through function

## Options

- Automatic width adjustment
- Mechanical Stopper
- Different belt width and chain system
- Safety interlocker
- Speed control



Vacuum stubs

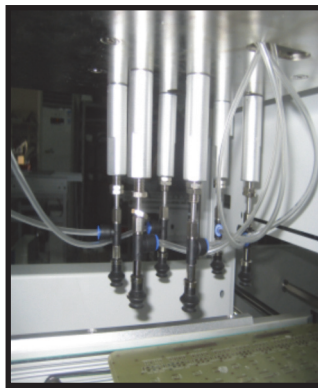

Magnetically placed stubs



## Technical Parameters

Description	Used for loading bare board PCB's into the line when it's not possible to use a destacker
Max. PCB Capacity	150 mm space for boards
PCB Time Feed	Approx. 10 seconds
Power Source	AC 220V, 50/60Hz, 1 phase
Power Consumption	300 Max
Air Pressure & Consume	4-6 bar, 30 l/min Max.

## Schematic

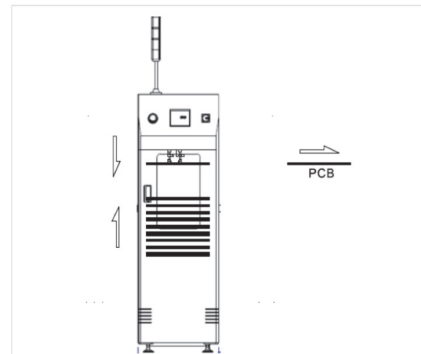

Size	Model	Machine Dimension (LxWxH) in mm	Effective PCB Size (LxW) in mm	Weight (Kg)
L	WHM-310SD3TL	505x940x1170	50x50-380x320	180
XL	WHM-310SD3TXL	605x1000x1170	50x50 - 530x460	200



# Destacker/Push-up Stacker



## Features

- User friendly soft touch LED membrane control panel
- Smooth and parallel width adjustment by leadscrew
- Small machine footprint
- Conveyor height 950 ± 30mm
- SMEMA compatible
- Pass-through function

## Options

- Automatic width adjustment
- Motorized width adjustment
- Touch screen
- Speed control
- Different belt width and chain system
- Safety interlocker

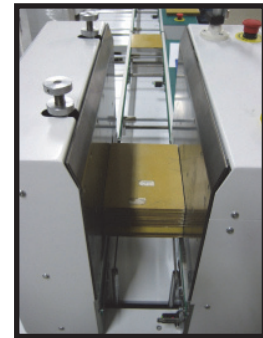

Close-up views

## Technical Parameters

Description	These units are for loading or restacking bare board PCB's in/off the line
Belt Type	Antistatic Flat Belt of 3mm width
Max. PCB Capacity	Up to 7 Kg at most
Power Source	AC 220V, 50/60Hz, 1 phase
Power Consumption	300 Max
Air Pressure & Consume	4-6 bar, 30 l/min Max.

## Schematic

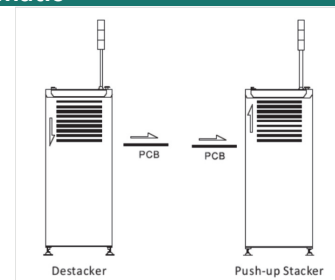

## Specification

Units in mm

Machine Type	Size	Model	Machine Dimensions(LxWxH) in mm	Effective PCB Size (LxW) in mm	Weight (Kg)
Destacker	L	WHM-283SD3BL	503x889x1200	50x65 - 400x460	180
	XL	WHM-283SD3BXL	600x1040x1200	50x65 - 530x460	249
Push-up Stacker	L	WHM-281SD3BL	503x889x1200	50x65 - 400x460	180
	XL	WHM-281SD3BXL	600x1040x1200	50x65 - 530x460	249

# Vacuum Loader for LED Lights

## Features

- User friendly touch screen control
- Enclosed design to ensure a high level of safety
- Adjustable vacuum stubs positions with magnets
- 3 or 8 nozzles type available to select depending on the PCB surface
- Conveyor height  $950 \pm 30$ mm
- SMEMA compatible

## Options

- Automatic width adjustment
- Mechanical Stopper
- Different belt width and chain system
- Safety interlocker
- Speed control

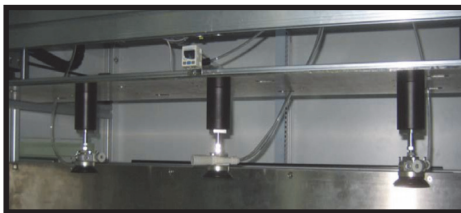

3 big nozzle version



8 small nozzle version

## Technical Parameters

Description	Used for loading long LED bare board PCB's into the line
Max. PCB Capacity	250 mm space for boards
PCB Time Feed	Approx. 10 seconds
Power Source	AC 220V, 50/60Hz, 1 phase
Power Consumption	300 Max
Air Pressure & Consume	4-6 bar, 30 l/min Max.

## Schematic

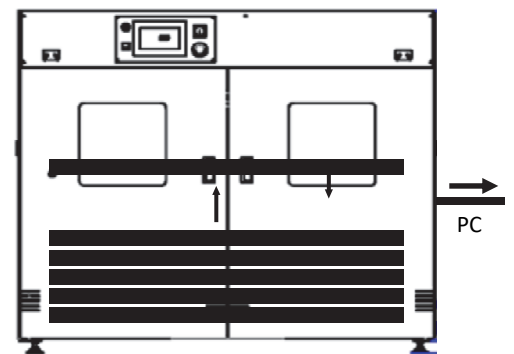

## Specification

Units in mm

Size	Model	Machine Dimensions (LxWxH)	Effective PCB Size (LxW) in mm	Weight (Kg)
L	WHM-311SD3TL	1500X1028X1519	50X50 - 1200X300	420
XL	WHM-315SD3TXL	1700x1364x1519	50x50 - 1500x300	500

## ■ Unloader for LED Lights



### Features

- User friendly soft touch LED membrane control panel
- Self diagnostic Error code display
- Adjustable vacuum stubs positions with magnets
- 3 or 8 nozzle type available
- Pressure regulated pusher to prevent board damage
- Conveyor height  $950 \pm 30$ mm
- SMEMA compatible

### Options

- Automatic width adjustment
- Mechanical Stopper
- Touch Screen
- Different belt width and chain system
- Safety interlocker
- Speed control

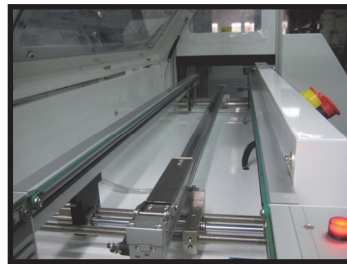

Long entrance conveyor



Makes Use of Triple magazines

### Technical Parameters

Description	These units are used for unloading LED bear board off the line when it's not possible to use a normal unloader
Max. PCB Capacity	250 mm space for boards
PCB Time Feed	Approx. 10 seconds
Power Source	AC 220V, 50/60Hz, 1 phase
Power Consumption	300 Max
Air Pressure & Consume	4-6 bar, 30 l/min Max.

### Schematic

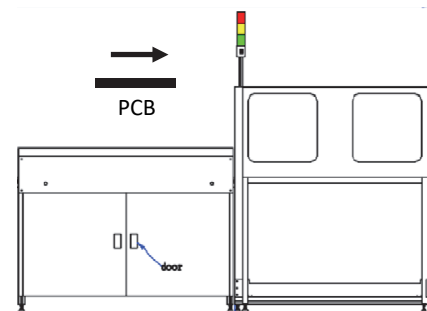

### Specification

Units in mm

Size	Model	Machine Dimensions (LxWxH) in mm	Rack size (LxWxH) in mm	Effective PCB Size (LxW) in mm	Weight (Kg)
M	WHM-304SD3BM	2810x1424x1716	800x320x563	50x50 - 800x250	450
L	WHM-304SD3BL	3450x1600x1716	1200x380x563	50x50 - 1200x300	500

# Multi Magazine Loader/Unloader



**LOADER**



**UNLOADER**

## Features

- User friendly soft touch LED membrane control panel
- Top & bottom pneumatic clamps to secure magazine rack
- Self diagnostic Error code display
- Pressure regulated pusher to prevent board damage
- Conveyor height 950 ± 30mm
- SMEMA compatible

## Options

- Touch screen control
- Motorized/Automatic width adjustment
- Safety interlockers
- Different belt width and chain system
- Universal type (Multiple magazine sizes)

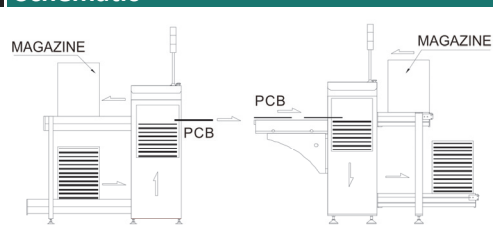
Technical Parameters		Schematic	
Description	These units are used for loading and unloading PCBs on/off the line		
Capacity	Up: 1 rack; Down: 2 racks		
Magazine Change Time	Approx. 30 seconds		
Power Source	AC 220V, 50/60Hz, 1 phase		
Power Consumption	300 Max		
Air Pressure & Consume	4-6 bar, 10 l/min Max.		

Specification						
Machine Type	Size	Model	Rack Size(LxWxH)	Machine Dimensions (LxWxH)	Effective PCB Size	Weight (Kg)
LOADER	M	WHM-300SD0BM-C	355x320x563	1365x769x1795	50x50 - 330x250	270
	L	WHM-300SD0BL-C	460x400x563	1650x845x1795	50x50 - 445x330	300
	LL	WHM-300SD0BLL-C	535x460x570	1868x898x1795	50x50 - 460x390	400
	XL	WHM-300SD0BXL-C	535x530x570	1800x979x1795	50x50 - 530x460	410
UNLOADER	M	WHM-301SD3BM-C	355x320x563	1898x769x1795	50x65 - 330x250	325
	L	WHM-301SD3BL-C	460x400x563	2454x846x1795	50x65 - 445x330	355
	LL	WHM-301SD3BLL-C	535x460x570	2604x898x1795	50x65 - 460x390	460
	XL	WHM-301SD3BXL-C	535x530x570	2632x973x1795	50x65 - 530x460	470

# Mini Magazine Loader/Unloader



**MINI LOADER**



**MINI UNLOADER**

## Features

- Especially for factories with limitations of space
- User friendly soft touch LED membrane control panel
- Top & bottom pneumatic clamps to secure magazine rack
- Self diagnostic Error code display
- Pressure regulated pusher to prevent board damage
- Conveyor height  $950 \pm 30$ mm
- SMEMA compatible

## Options

- Touch screen control
- Motorized/Automatic width adjustment
- Safety interlockers
- Different belt width and chain system
- Universal type (Multiple magazine sizes)

## Technical Parameters

Description	These units are used for loading and unloading PCBs on/off the line
Capacity	Up: 1 rack; Down: 1 rack
Magazine Change Time	Approx. 30 seconds
Power Source	AC 220V, 50/60Hz, 1 phase
Power Consumption	300 Max
Air Pressure & Consume	4-6 bar, 10 l/min Max.

## Schematic

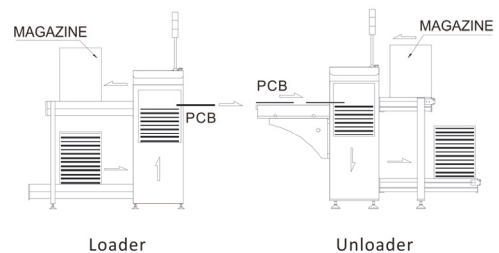

## Specification

Machine Type	Size	Model	Rack Size(LxWxH)	Machine Dimensions (LxWxH)	Effective PCB Size	Weight (Kg)
LOADER	M	WHM-320SD0BM-C	355x320x563	1100x766x1670	50x50 - 330x250	150
	L	WHM-320SD0BL-C	460x400x563	1300x850x1670	50x50 - 445x330	190
	LL	WHM-320SD0BLL-C	535x460x570	1646x905x1670	50x50 - 460x390	230
	XL	WHM-320SD0BXL-C	535x530x570	1646x973x1670	50x50 - 530x460	270
UNLOADER	M	WHM-321SD3BM-C	355x320x563	1618x765x1670	50x65 - 330x250	185
	L	WHM-321SD3BL-C	460x400x563	1760x850x1670	50x65 - 445x330	230
	LL	WHM-321SD3BLL-C	535x460x570	1834x1033x1670	50x65 - 460x390	275
	XL	WHM-321SD3BXL-C	535x530x570	2009x1103x1670	50x65 - 530x460	320

# 90 Degrees Unloader

## Features

- User friendly control panel
- Top & bottom pneumatic clamps to secure magazine rack
- Self diagnostic Error code display
- Pressure regulated pusher to prevent board damage
- Front or Rear unloading to reduce machine length
- Conveyor height  $950 \pm 30$ mm
- SMEMA compatible

## Options

- Touch screen control
- Motorized/Automatic width adjustment
- Safety interlockers
- Different belt width and chain system
- Universal type (Multiple magazine sizes)



Rear magazine ramps



## Technical Parameters

Description	These units are used for unloading PCBs out of the line through the front or rear side
Capacity	Up: 1 rack; Down: 1 rack
Magazine Change Time	Approx. 30 seconds
Indexing Pitch	10, 20, 30, 40mm or specify
Power Source	AC 220V, 50/60Hz, 1 phase
Power Consumption	300W Max.
Air Pressure & Consume	4-6 bar, 10 l/min Max.

## Schematic

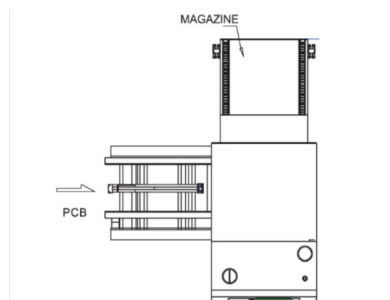

## Specification

### Units in mm

Size	Model	Machine Dimensions (LxWxH) in mm	Effective PCB Size (LxW) in mm	Rack Size (LxWxH) in mm	Weight (Kg)
M	WHM-303SD3BM-C	1036x1621x1682	50x65 - 330x250	355x320x563	400
L	WHM-303SD3BL-C	1240x1896x1682	50x65 - 445x330	460x400x563	420
LL	WHM-303SD3BLL-C	1300x1969x1682	50x65 - 530x390	535x460x570	440
XL	WHM-303SD3BXL-C	1410x2069x1682	50x65 - 530x460	535x530x570	460

# Single Magazine Unloader



## Features

- User friendly soft touch LED membrane control panel
- Especially for factories with limitations of space
- Top & bottom pneumatic clamps to secure magazine rack
- Self diagnostic Error code display
- Pressure regulated pusher to prevent board damage
- Rear door to load/unload a magazine inside the machine
- Conveyor height  $950 \pm 30$ mm
- SMEMA compatible

## Options

- Touch screen control
- Motorized/Automatic width adjustment
- Safety interlockers
- Different belt width and chain system
- Universal type (Multiple magazine sizes)



Rear Door

## Technical Parameters

Description	These units are used for unloading PCBs out of the line when there is space limitation
Capacity	1 single magazine
Magazine Change Time	Approx. 30 seconds
Indexing Pitch	10, 20, 30, 40mm or specify
Power Source	AC 220V, 50/60Hz, 1 phase
Power Consumption	300W Max.
Air Pressure & Consume	4-6 bar, 10 l/min Max.

## Schematic

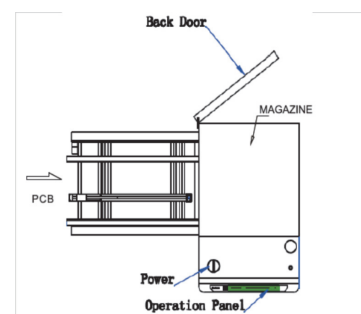

## Specification

Units in mm

Size	Model	Machine Dimensions (LxWxH) in mm	Effective PCB Size (LxW) in mm	Rack Size (LxWxH) in mm	Weight (Kg)
M	WHM-302SD3BM-C	1032x819x1682	50x65 - 330x250	355x320x563	400
L	WHM-302SD3BL-C	1186x900x1682	50x65 - 445x330	460x400x563	420
LL	WHM-302D3BLL-C	1413x951x1682	50x65 - 530x390	535x460x570	440
XL	WHM-302SD3BXL-C	1434x1028x1682	50x65 - 530x460	535x530x570	460

# NG/OK UNLOADER

## Dual Magazine Unloader



### Features

- User friendly soft touch screen control
- Top & bottom pneumatic clamps to secure magazine rack
- Automatic shuttle moves the board to the desired rack exit for NG function, or dual magazine configuration.
- Pressure regulated pusher to prevent board damage
- Conveyor height  $950 \pm 30$ mm
- SMEMA compatible

### Options

- Motorized/Automatic width adjustment
- Safety interlockers
- Different belt width and chain system
- Universal type (Multiple magazine sizes)

### Technical Parameters

Description	These units are used for unloading PCBs off the line, in a dual magazine, or in an NG/OK selection mode.
Capacity	Up: 2 racks; Down: 4 racks
Magazine Change Time	Approx. 30 seconds
Indexing Pitch	10, 20, 30, 40mm or specify
Power Source	AC 220V, 50/60Hz, 1 phase
Power Consumption	300W Max.
Air Pressure & Consume	4-6 bar, 10 l/min Max.

### Schematic

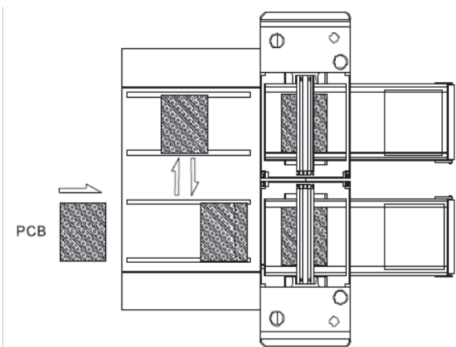

### Specification

Units in mm

Machine Type	Size	Model	Machine Dimensions) (LxWxH) in mm	Effective PCB Size ( LxW ) in mm	Rack Size (LxWxH)	Weight (Kg)
NG/OK UNLOADER	M	WHM-305SD3BM	1902x1527x1683	50x65 - 330x250	355x320x563	760
	L	WHM-305SD3BL	2298x1688x1683	50x65 - 445x330	460x400x563	820
	LL	WHM-305SD3BLL	2683x1940x1683	50x65 - 530x390	535x460x570	870
	XL	WHM-305SD3BXL	3083x2216x1683	50x65 - 530x460	535x530x570	980
DUAL MAG UN-LOADER	M	WHM-306SD3BM	1902x1527x1683	50x65 - 330x250	355x320x563	760



# Elevator Conveyor



## Features

- User friendly touch screen control panel
- Fast, smooth and precise positioning (Servomotor)
- Selectable system thresholds
- Smooth and parallel conveyor adjustment (lead screw)
- Automatic width adjustment
- SMEMA compatible
- Two types: high elevator (for top return lines) and low elevator (for bottom return lines)

## Options

- Safety interlockers
- Different belt width and chain system
- Wheels to move the machine easily around



Lower return line



Upper return line

## Technical Parameters

Description	This unit is used to allow permanent passage across the line, or for loop-style installations.
Belt Type	Antistatic Flat Belt of 3mm width
Conveyor Speed	0.5-20m/min or specify
Power Source	AC 220V, 50/60Hz, 1 phase
Power Consumption	100 Max
Cycle time	10 sec

## Schematic

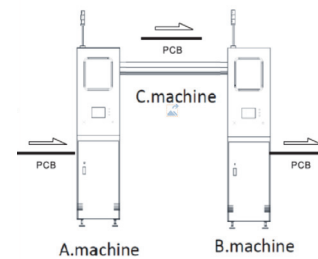

## Specification

Units in mm

Size	Model	Machine Dimensions (LxWxH) in mm	Effective PCB Size (LxW) in mm	Weight (Kg)
L	WHM-02624SD3T L	550x975x2608	50x50 - 445x330	350
XL	WHM-02624SD3TXL	640x1035x2608	50x50 - 530x460	450
L	WHM-02601SD3TL	550x1012x1982	50x50 - 445x330	350
XL	WHM-02601SD3TXL	635x1142x1982	50x50 - 530x460	400

# Insertion Conveyor



## Features

- Modular design, PLC controlled
- Stability enhanced by heavy design
- Smooth and parallel width adjustment (stainless steel screws)
- Automatic/Manual modes
- Shelf for ESD component boxes
- Light system for better inspection
- Variable speed control
- SMEMA compatible
- Conveyor height  $950 \pm 30\text{mm}$

## Options

- Support for Monitor
- Motorized width adjustment
- Choice of different chain transport system
- Mechanical stopper
- Foot pedal pass control

## Technical Parameters

Description	This unit is used in a manual line before soldering section. For the operator to insert components manually.
Belt Type	Pin chain
Conveyor Speed	0.5-20m/min or specify
Power Source	AC 220V, 50/60Hz, 1 phase
Power Consumption	100W Max.

## Schematic

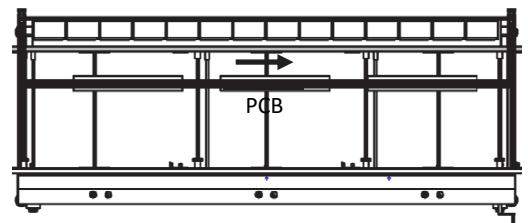

## Specification

Units in mm

Size	Model	Machine Dimensions(LxWxH) in mm	Effective PCB Size (LxW) in mm	Weight (Kg)
XL	WH-S270SDNBXL-DW	2700x1019x1786	50x50 - 445x460	400

# Flat Belt Conveyor



## Features

- Modular design, PLC controlled
- Buzzer
- Variable speed control
- Flat belt of 500mm width
- Signal Tower

## Options

- Different lengths available on demand

## Technical Parameters

Description	Flat belt conveyor to transport boards after reflow oven mesh belt, and accumulate them.
Belt Type	500mm wide flat belt
Conveyor Speed	0.5-20m/min or specify
Power Source	AC 220V, 50/60Hz, 1 phase
Power Consumption	100W MAX

## Schematic

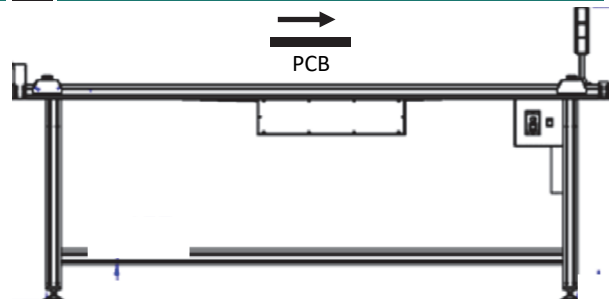

## Specification

Units in mm

Model	Machine Dimensions (LxWxH) in mm	Effective PCB Size (LxW) in mm	Weight (Kg)
WH-C250SD500BXL-L	2500X795x1254	50x50-2000x490	120

# PCB Cleaning Machine

## Features

- Real-Time Electrostatic Monitoring System
- The system could save 30 days' monitoring data.
- User friendly touch screen control panel
- Keyence Ionizer to remove static electricity
- Pull-out design for cleaning machine
- Conveyor height 950±30mm
- SMEMA compatible
- Three types on request: single side, double side or selectable

## Options

- External brush with vacuum to absorb out dust
- Additional ionizers for better static elimination
- Automatic width adjustment
- Safety interlocker

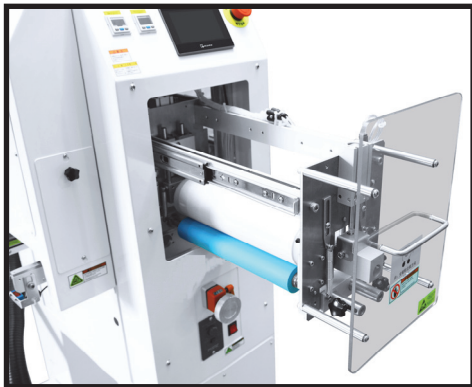

The cleaning roller



## Technical Parameters

Description	This unit is used to remove the foreign objects from the PCB surface. It can also eliminate the static electricity on of PCB
Belt Type	Antistatic Flat Belt of 8mm width
Cycle Time	Approx. 8 seconds
PCB Thickness	0.6-3mm Max. 4mm
Conveyor Speed	0.5-20m/min or specify
Power Source	AC 220V, 50/60Hz, 1 phase
Power Consumption	150W Max
Air Pressure & Consume	4-6 bar, 10 l/min Max.

## Schematic

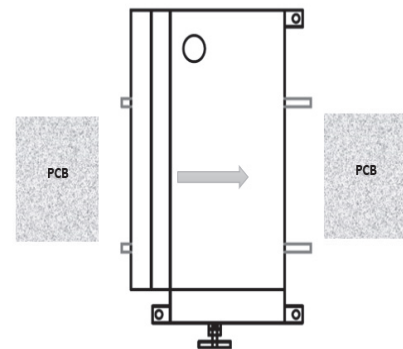

## Specification

Units in mm

Type	Model	Machine Dimensions (LxWxH)	Effective PCB Size (LxW)	Weight (Kg)
Single Side	WHM-055SD3TL	550x650x1350	80x80 - 445x330	160
Double Side	WHM-056SD3TL	550x650x1350	150x80 - 445x330	180
Selectable	WHM-057SD3TL	550x650x1350	150x80 - 445x330	200

# Wave Outfeed Conveyor

## Belt wave outfeed conveyor



### Features

- Variable speed control
- Flat belt of 500mm width

### Options

- Cooling fans on top
- Extension conveyor available on demand

## Chain wave outfeed conveyor



### Features

- Modular design, PLC controlled
- Variable speed control
- 3mm pin chain conveyor
- Sliding resistors on inclined section

### Options

- Cooling fans on top
- Motorized width adjustment

### Technical Parameters

Description	This unit is used to unload PCBs or pallets from a wave soldering machine.
Belt Type	Flat belt or chain
Conveyor Speed	0.5-20m/min or specify
Power Source	AC 220V, 50/60Hz, 1 phase
Power Consumption	100W MAX

### Schematic

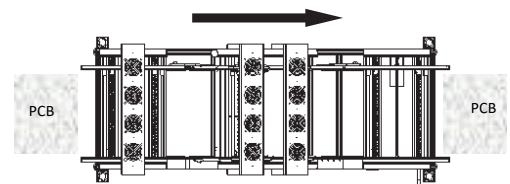

### Specification

Units in mm

Type	Model	Machine Dimensions (LxWxH) in mm	Effective PCB Size (LxW) in mm	Weight (Kg)
Flat Belt	WH-C130SD500BXL	1350x685x1335	50x50-550x490	120
Chain	WH-C250SDNBXL	2500x976x1446	200x200-550x610	400

# Automation Lines Examples

## CASE 1

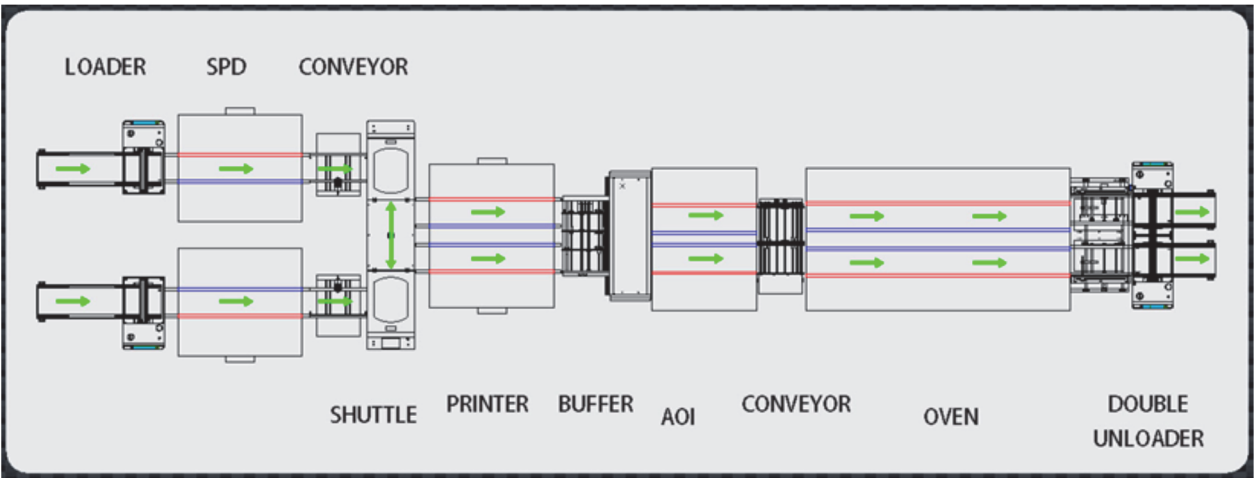

## CASE 2

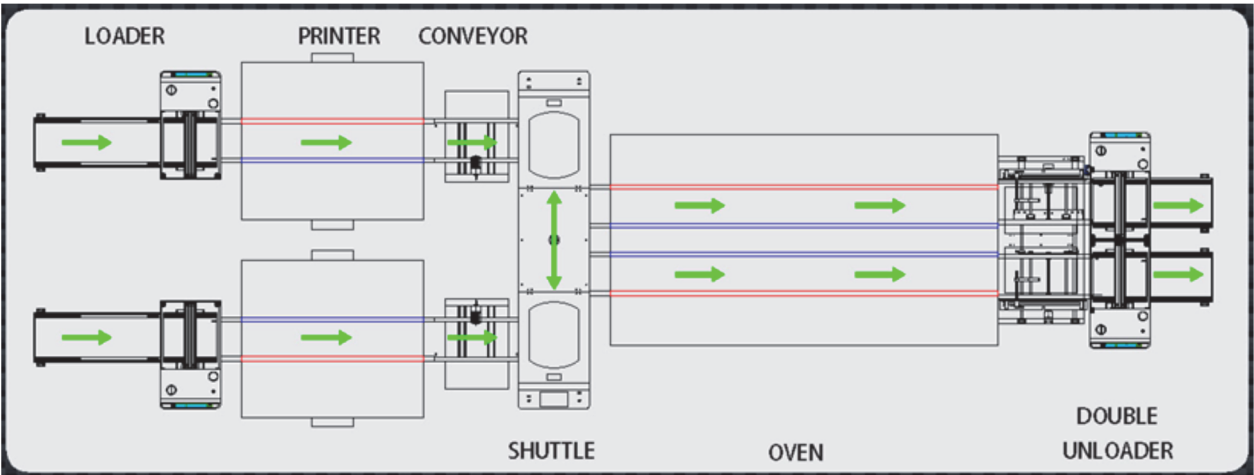

## CASE 3

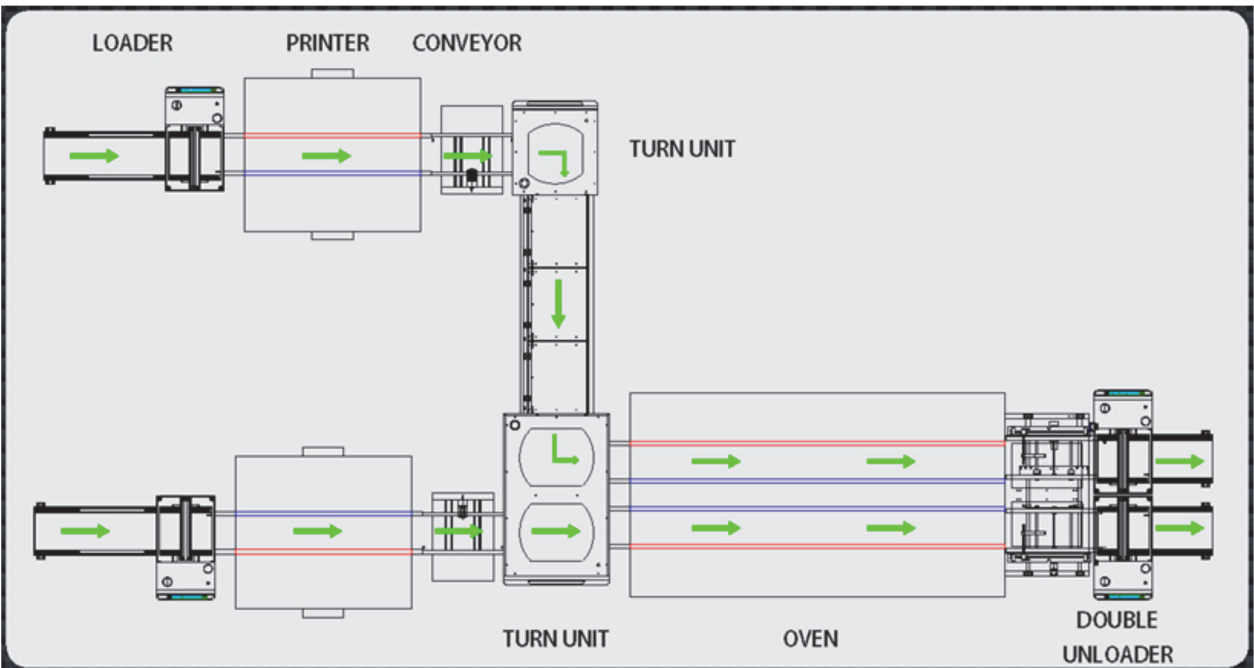

## Customers World Wide

### Important Clients



## Quality Assurance

### Product reliability is our constant goal

### Research & Development

Our R&D department is committed to the integration of customer needs and the requirements of the SMT process. Our design concept is to reduce product maintenance rate, accelerate the speed of the maintenance, and improve the PCB automation process between equipment.

### Quality Control

We ensure that our products are of high reliability. The implementation of the ISO9001 quality control system in our manufacturing plant is just one of the taken measures.

We perform inspections, production process controls and functional tests by qualified engineers for all our orders, plus a final quality control by a European engineer previous to any shipment world wide.



## Agent Network





## ■ After-sale Service

We believe that support is important, and that's why we select the best companies to be our agents world wide, highly specialized enterprises which have a team of well-trained engineers that will offer maintenance and support for all the lines that we have supplied.

Very important is also the after-sales support that we supply to each of our agents, with direct communication when required, fast delivery of spare parts in case of need, and technical assistance by phone or other electronic means. We believe that a fast support at the customer's side is the answer to a successful business.



Automation installation in a PVA coating line



Our own booth at SMT Hybrid Packaging in Germany



Our conveyors at Productronica Show in Germany

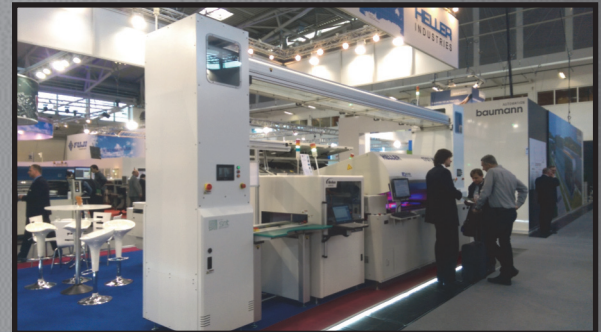

Return line for demo at Productronica Show in Germany



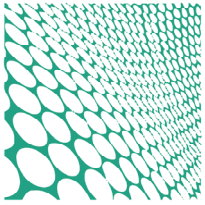

e-flex  
**smt**  
microsystems

**e-Flex SMT Microsystems, Co., Ltd.**

Room 1004, Tung Wah Mansion  
199-203 Hennessy Rd.

Wan Chai, Hong Kong

Tel.: +852 3529 1071

Fax: +852 3529 1070

Email: [info@eflexsmt.com](mailto:info@eflexsmt.com)

[www.eflexsmt.com](http://www.eflexsmt.com)

Room 09, Bonham Circus  
40-44 Bonham Street  
Sheung Wan, Hong Kong

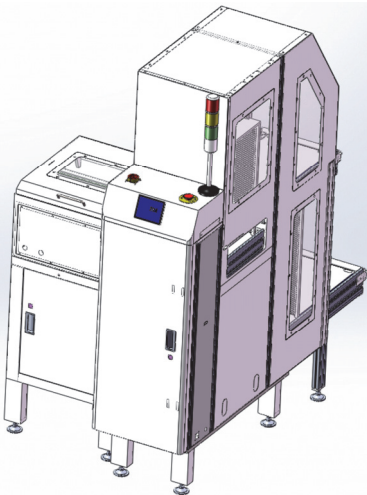

**Magazine Buffer**

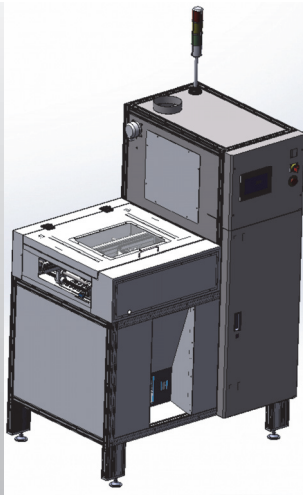

**Curing Buffer**

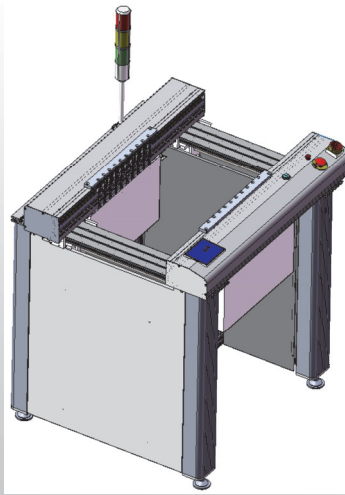

**Reject Conveyor**

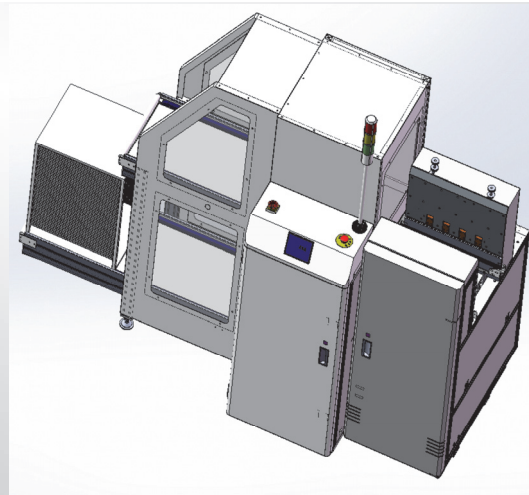

**Loader/Destacker Combo**

Follow us in

**2018**

