



3D Solder Paste Inspection Machine (3D SPI)

3Si Series

SAKI's 3D SPI Series is designed
for the Smart Factory Connection



Global Network

Saki Corporation Headquarters Office

DMG MORI Tokyo Digital Innovation Center,
3-1-4, Edagawa, Koto-ku, Tokyo, 135-0051,
Japan
Tel. +81-3-6632-7910
Fax. +81-3-6632-7915

Saki Corporation Nagoya Office

DMG MORI Nagoya Head Office 4F,
2-35-16 Meieki, Nakamura-ku, Nagoya-shi,
Aichi, 450-0002, Japan
Tel. +81-52-587-1853
Fax. +81-52-587-1854

Saki Corporation West Japan Office

106 Kitakoriyama-cho, Yamatokoriyama-shi,
Nara, 639-1160, Japan
Tel. +81-743-87-9845
Fax. +81-743-87-9950

Saki (Shanghai) Co., Ltd.

No.178 West YinDu Road, Songjiang District,
Shanghai 201612, China
Tel. +86-21-6282-2266
Fax. +86-21-5230-5002

Saki (Shanghai) Co., Ltd. Shenzhen Branch Office

Room 209-12, Building 8, 1970 Science and
Technology Park, No.112, Min Kang Road,
Longhua District, Shenzhen 518109, P.R.China
Tel. +86-755-2583-8315
Fax. +86-755-2583-8317

Saki Taiwan Co., Ltd.

No.61, Ln.199, Sec.1, Zhongshan N. Rd.,
Yangmei Dist., Taoyuan City 326021,
Taiwan(R.O.C)
Tel. +886-3-478-5799
Fax. +886-3-478-5766

Saki Corporation Korea Office

DMG MORI Tech Center 4F,
12, Ilijik-ro 106beon-gil, Manan-gu,
Anyang-si, Gyeonggi-do, Republic of Korea
Tel. +82-(0)31-361-5621
Fax. +82-(0)31-361-5628

Saki Asia Pacific Pte, Ltd.

2 Ang Mo Kio St. 64 #03-09A
Econ Industrial Building 569084, Singapore
Tel. +65-6483-9330
Fax. +65-6853-5730

Saki Asia Pacific (Thailand) Co., Ltd.

200 Moo 4, Jasmine International Tower,
14th Floor, Unit 1403B, Chaengwattana Road,
Pakkred Pakket, Nonthaburi 11120, Thailand
Tel. +66-2-100-3480
Fax. +66-2-100-3460

Saki Europe GmbH

Landsberger Strasse 183,
D-80687 Munich, Germany
Tel. +49-89-309-04-69-0
Fax. +49-89-309-04-69-99

Saki Europe GmbH Czech (Prague) Office

Severní 334, 252 25 Ořech,
Czech Republic
Tel. +420-311-36-37-36
Fax. +420-311-36-37-37

Saki America, Inc. Chicago Office

2400 Huntington Blvd,
Hoffman Estates,
IL 60192, U.S.A
Tel. +1-508-878-8267

Saki America de Mexico, S.A. de C.V.

Av. Vallarta 6503, Local F67, Col. Ciudad
Granja, C.P. 45010, Zapopan, Jal., Mexico
Tel. +52 33-3857-6488

saki Saki Corporation

Headquarters

DMG MORI Tokyo Digital Innovation Center
3-1-4, Edagawa, Koto-ku, Tokyo, 135-0051, Japan
TEL: +81-3-6632-7910 FAX: +81-3-6632-7915

Global Network

<https://www.sakicorp.com/en/>

QUALITY DRIVEN Production



SAKI maximizes production efficiency by improving production-line quality.

Today's technologies and markets demand advanced manufacturing, high-mix low-volume production, precision quality, short lead times, and low total cost-of-ownership. Saki's high-speed, high-accuracy inspection and measurement systems, with enhanced software and hardware platforms, satisfy those requirements.

Saki's data capture capabilities and machine-to-machine (M2M) connectivity maximize production efficiency for the Smart Factory.

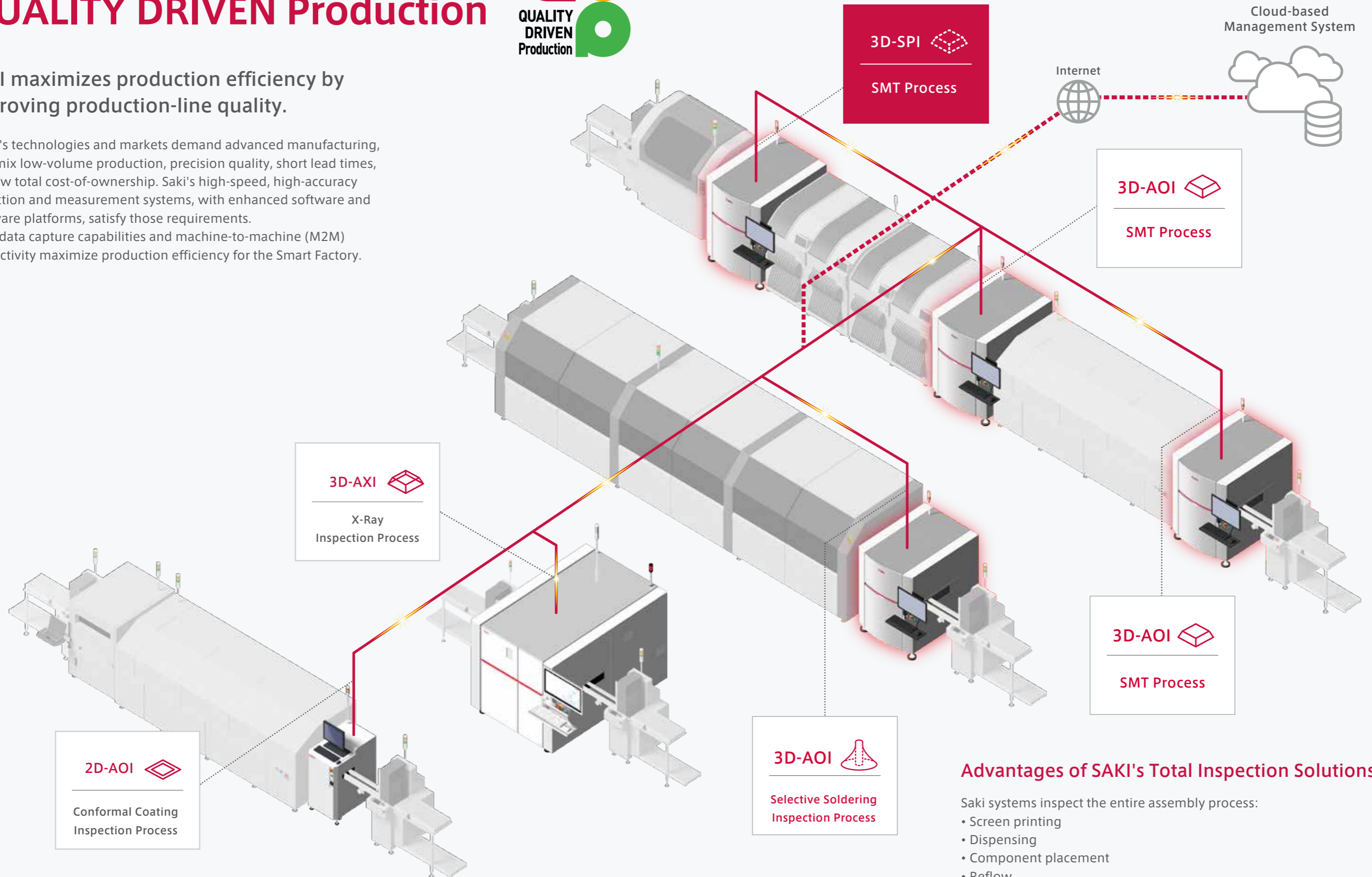

Advantages of SAKI's Total Inspection Solutions

Saki systems inspect the entire assembly process:

- Screen printing
- Dispensing
- Component placement
- Reflow
- Selective soldering
- Conformal coating

Quality First



SAKI's 3D-SPI systems enable increased production efficiency of the entire line with remarkable speed, as well as increased product and performance quality and takt-time control.



Benefits provided with Saki's 3D-SPI series

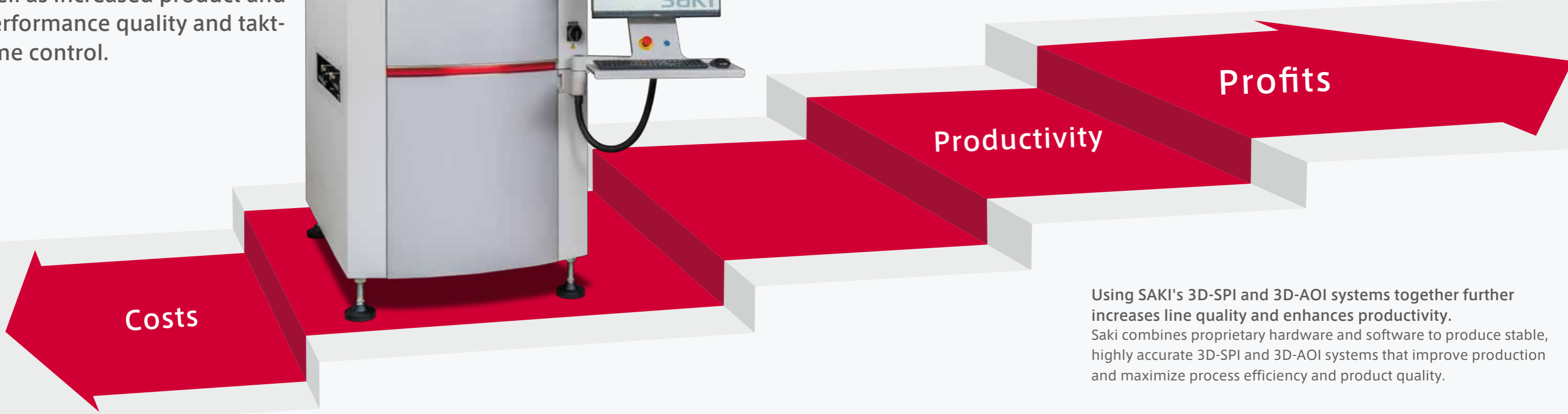

Using SAKI's 3D-SPI and 3D-AOI systems together further increases line quality and enhances productivity. Saki combines proprietary hardware and software to produce stable, highly accurate 3D-SPI and 3D-AOI systems that improve production and maximize process efficiency and product quality.

Key Factor 1 Advanced Hardware Features

- Machine Stability and Accuracy**
- Same rigid gantry structure as Saki's 3D-AOI
 - Self-diagnostic functions
 - Rigid gantry structure and dual motor-drive system
 - High resolution linear scale for accurate positioning
- Speed**
- Increased conveyor speed
 - CoaXPress camera for faster inspection & measurement process
- Flexible Configurations for Diverse Requirements**
- Simultaneous 2D and 3D inspection of the entire board
 - Scalable optical resolutions of 7µm, 12µm, and 18µm
 - Flexible gantry for M/L/XL PCBA sizes and dual lanes



Key Factor 2 Advanced Software Features

- Programming**
- One common platform supports 3D-SPI, 3D-AOI, and 3D-AXI
 - Saki Self-Programming (SSP) Software
- Speed**
- Newly developed high-speed mode increases measurement and inspection speed by about 190%
- Measurement and Inspection/SPC Function**
- Warpage adjustment
 - Coplanarity inspection
 - SPC function
- Verification**
- History Management System for data logging and history
 - Golden & Silver Sample Check Function for process verification



Key Factor 3 Applied Technology

- Machine-to-Machine Systems**
- Feed-back from SPI to Printer
 - Feed-forward from SPI to Pick-and-Place
 - Feed-back from AOI to Pick-and-Place
- Stand-alone Systems**
- RMS remotely manages multiple BF2-Monitors with one PC
 - MPV lets operators see every inspection result in real time

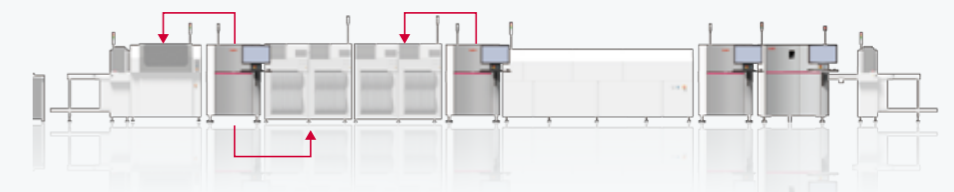

SAKI Technology for M2M Communication



Key Factor 1 Advanced Hardware Features

Proprietary hardware provides faster measurement and inspection and accurate measurements

- Saki's machines are built with hardware that's made to last.
- A closed-loop, dual servo motor-drive system, high-resolution linear scale, and rigid gantry structure provide unsurpassed accuracy and repeatability for absolute measurements.
- An optimized conveyor system, driven by step motors, enables fast PCBA loading and unloading.
- Both the 3D-AOI and 3D-SPI systems have the same rigid gantry structure that offers high accuracy.

Self-diagnostic System

Saki's predictive and preventive maintenance management system assures stable machine conditions and repeatable, consistent performance. Every key component is monitored along with system conditions, and a detailed diagnostic log is recorded. The optimized preventive maintenance plan reduces maintenance time, machine down-time, manpower, and costs.

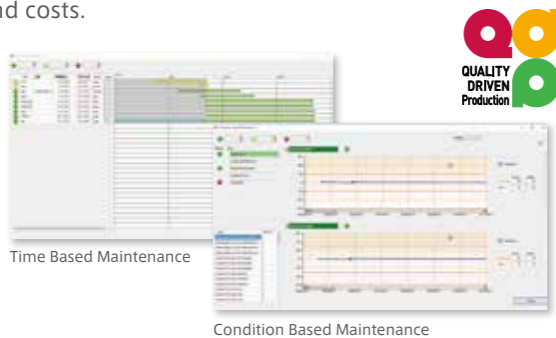

Simultaneous 2D and 3D inspections over the entire board

- 3D-SPI uses both 2D and 3D images for inspection.



Optical Unit

- Three camera resolution levels —7 μ m, 12 μ m, 18 μ m— are available to match application requirements.
- Multi-frequency digital projectors (12 μ m & 18 μ m-Two, 7 μ m-Four) provide accurate 3D measurements for high-quality images and quantitatively detect solder printing failures.
- Enhanced 2D and 3D calibration uses multiple calibration height targets for positive and negative heights to guarantee height measurement accuracy.

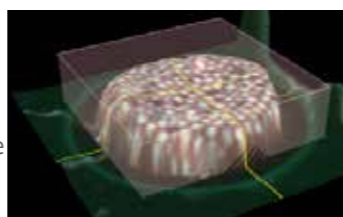

Remarkable Speed

Equipped with newly developed technologies and features

- Both 3D-AOI and 3D-SPI have optimized conveyor systems, driven by step motors, in similar enclosures, enabling fast PCBA loading and unloading.
- The CoaXPress camera enables faster inspection.
- A newly developed high-speed mode and unique imaging system increase measurement and inspection speed by about 190% compared to previous machines.

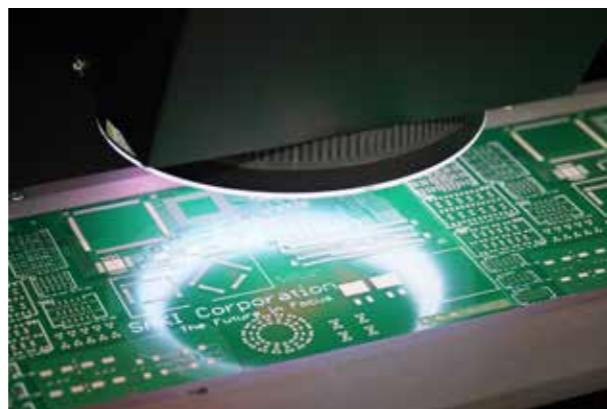

Key Factor 2 Advanced Software Features

Programming

Reduces set-up time, contributing to increased productivity

- Special BF2 software has a common user-interface for Saki's 3D SPI, AOI, and AXI systems.
- The software saves a complete 3D image of the whole PCBA, so the operator can create inspection data without using the physical board.

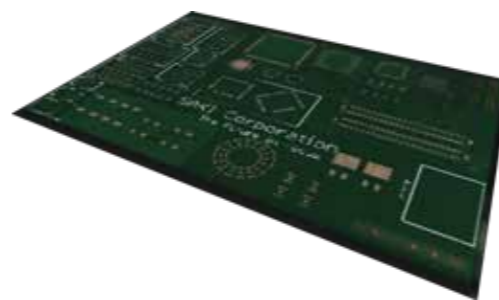

Creating programming data faster

- Saki Self-Programming (SSP) Software
- Saki's Self-Programming Function was developed on the concepts of Board less, Skill less, and Stress less. Inspection data can be easily created by using various PCB design data in addition to Gerber data and CAD data.

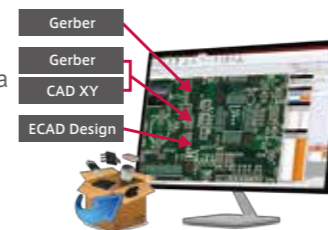

Measurement and Inspection

Saki's unique Warpage Adjustment provides stable inspection for boards with large warpage such as flexible printed circuits.

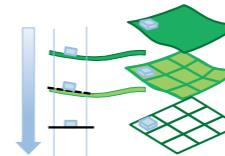

Coplanarity inspection

In addition to inspecting each solder deposit, we inspect the relative variations in the BGA to increase the quality of small and fine-pitch components.

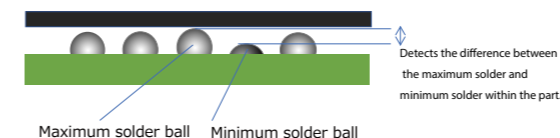

SPC Function

Trend View

Trend View Monitors inspection results during automatic operation and calculates sample values in real time. Through this function, the printed solder paste quality can be maintained and controlled for each board.

All Charts View



Defect Analysis



Yield Chart

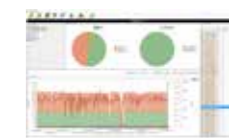

Past Board View

This function saves inspection results and measured values for one week. It enables you to search previously inspected boards from the saved data, sort them by placement data, reference, and component type, and primarily check the inspection results, measured values, failure types, and images of failures.

Inspection Data Verification

History Management System

The History Management System records the detailed data modification system in detail (who, what, when, where, why, and how)



Golden & Silver Sample Check Function

Maintains inspection accuracy by checking machine status and inspection conditions before starting auto operation.



Solution

Saki's QUALITY DRIVEN Production Solution

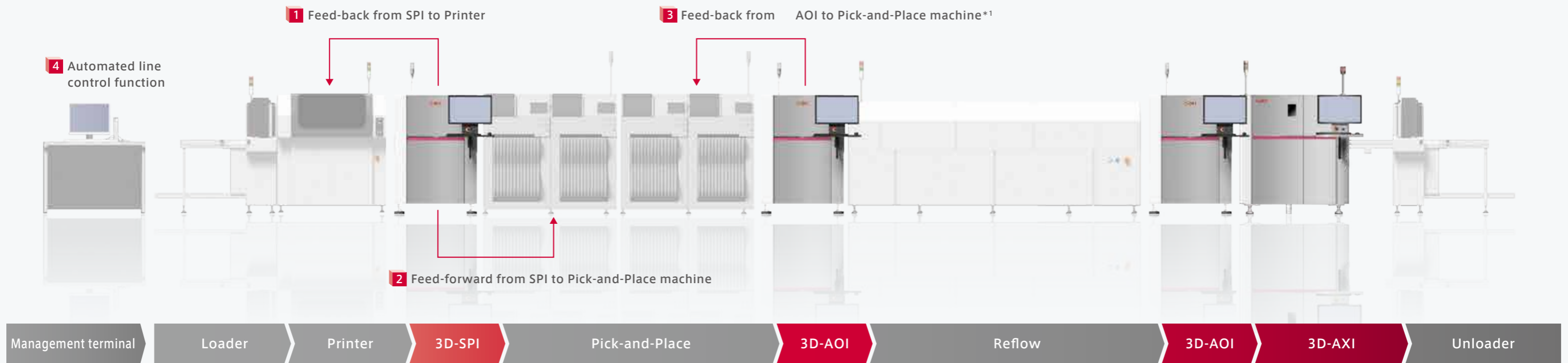

Key Factor 3

Applied Technology

M2M Solution

1 Feed-back from SPI to Screen Printer.

Feeds back misalignment data and prevents print errors by automatically alerting the user when the stencil needs cleaning.

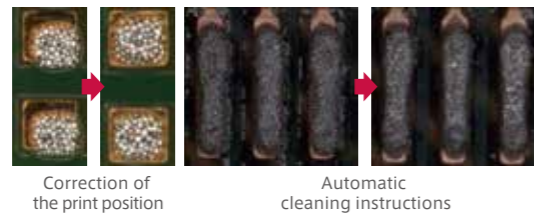

2 Feed-forward from SPI to Pick-and-Place machine

Measures the degree the printing position shifts to correct placement positioning. A NG board skip function improves efficiency, quality, and cost.



3 Feed-back from AOI to Pick-and-Place machine

Feeds back placement position and location data from AOI to pick-and-place and feeds forward data from SPI to improve quality and efficiency.

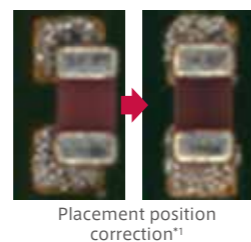

*1 factory installed option

4 Automated line control function

Automates control of the assembly line to reduce rework and waste and increase throughput.

※1~4 Saki partners with the leading PCB equipment manufacturers. Ask us which products we connect with.

Options

BF2-Editor

Create data and debug the process offline

BF2-Monitor (Offline verification terminal)

5 RMS (Remote Management System) Remotely control multiple BF2-Monitors with a single PC. Reduces assembly-floor personnel. Moreover, the production status of each device can be confirmed.

6 MPV (Multi Process View)

The BF2-Monitor shows the results of all inspection processes (SPI, pre-reflow, and post reflow) on one screen in real time for operator review, simplifying the verification process and making it less subject to error. It is also useful for analyzing the cause of a defective board.

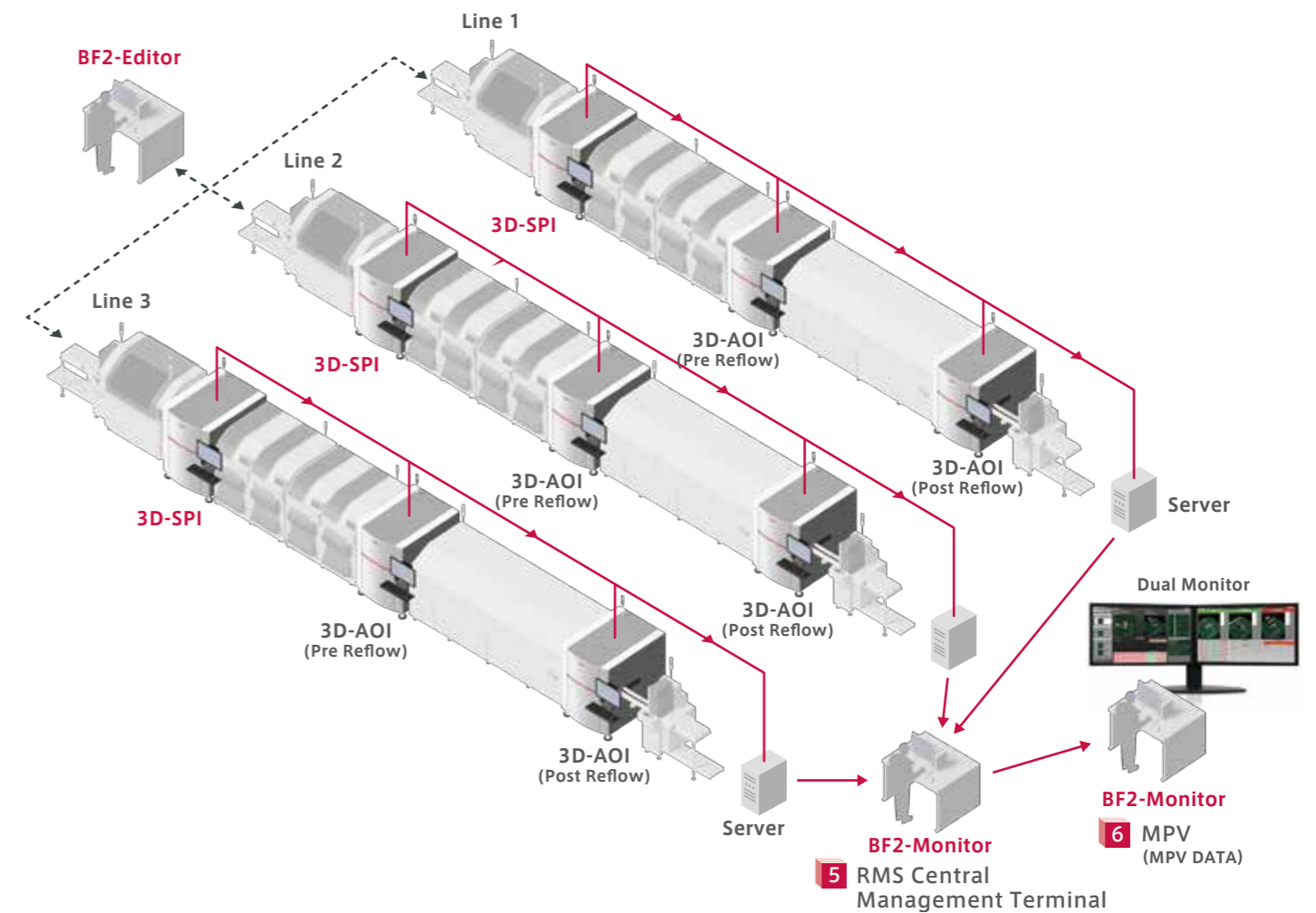

Product

3Si Series Product Specifications

Dual-lane system can inspect 2 different PCBAs simultaneously

Dimensions	M Single lane	M Dual lane	L Single lane	L Dual lane	XL Single lane	
Model Name	3Si-MS2	3Si-MD2	3Si-LS2	3Si-LD2	3Si-ZS2	
Size (W) × (D) × (H) (mm, in.)	850 × 1430 × 1500, 33.46 × 56.30 × 59.06		1040 × 1440 × 1500, 40.94 × 56.69 × 59.06		1340 × 1440 × 1500, 52.75 × 56.69 × 59.06	
Weight(kg,lb)	850kg, 1873.93lb		900kg, 1984.16lb			
Electric Power	Single Phase ~ 200-240V+/-10%, 50/60Hz					
Air Requirement	0.5MPa, 5L/min (ANR)					
PCB Size (mm, in.)	50×60~330×330, 1.97×2.36~12.99×12.99	Single mode	Dual mode	Single mode	Dual mode	50×60~686×870, 1.97×2.36~27.00×34.25
		—	—	—	—	
PCB Clearance	Top : 40mm, 1.57in. Bottom: 60mm, 2.36in.	Top : 40mm, 1.57in. Bottom: 50mm, 1.96in.	[7 μm camera head]	[7 μm camera head]	Top : 40mm, 1.57in. Bottom: 60mm, 2.36in.	
			[12/18 μm camera head]	[12/18 μm camera head]		

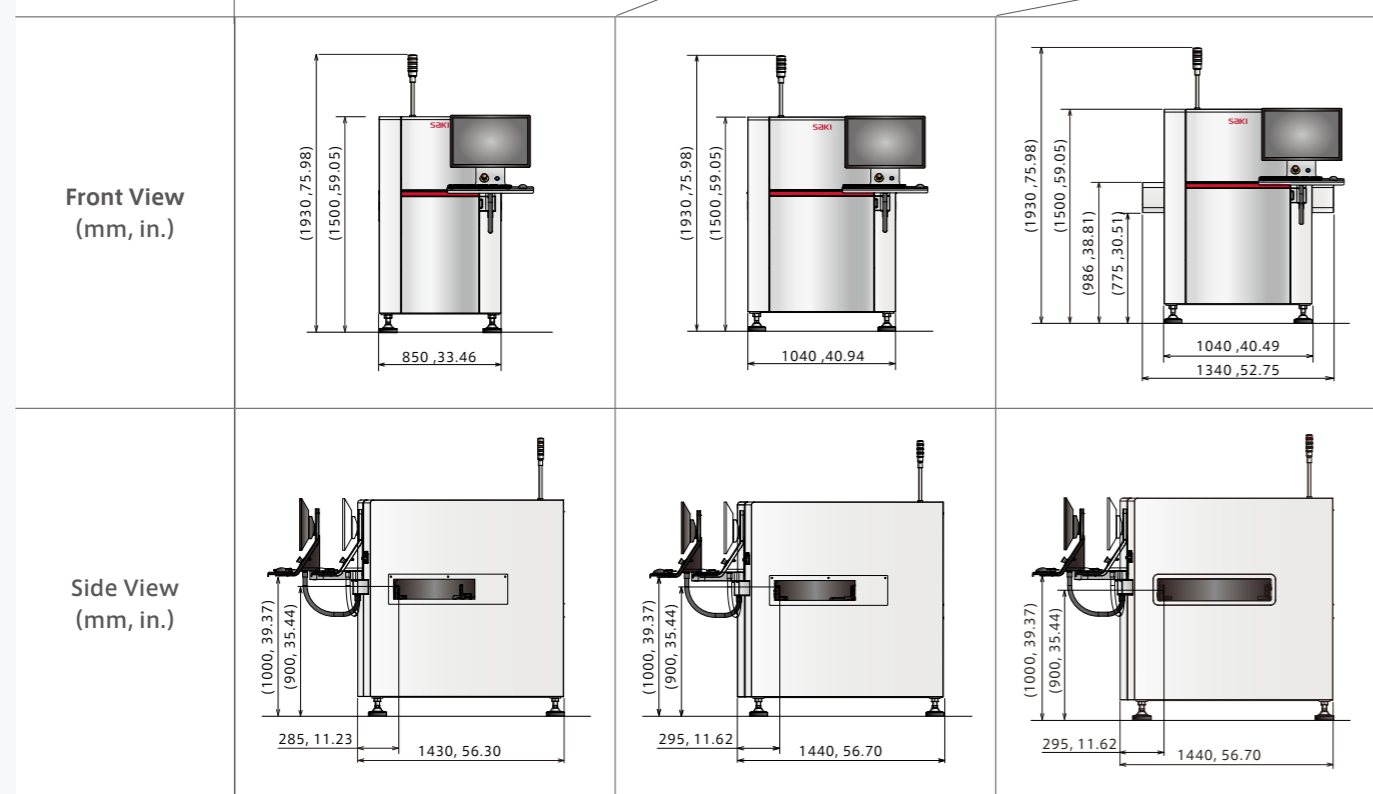

● 3Si-ZS2 supports the optical unit with resolution of 18μm.

3Si Series Optical Unit Specifications

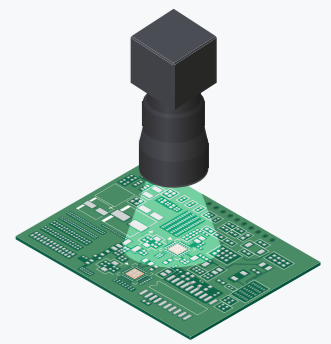

Wide selection of cameras based on various optical resolutions and speeds

Resolution	7 μm	12 μm	18 μm
Height measurement range	500 μm		
Image capture time	1,063mm ² /s 1,64in. ² /s	5,500mm ² /s 8,52in. ² /s	6,400mm ² /s 9,92in. ² /s
Major characteristics	Meets requirements for production of advanced smart phones, wearable devices, and devices and modules for IoT. Capable of 0201mm (008004in.) pad inspection.	Well balanced system offering both high speed and the inspection of the industry's smallest components.	Saki's new optical sensor increases speed by 190% delivering the industry's highest throughput.

← High-definition → High speed →

Substantially improves inspection speed

Comparison between BF-3Si and 3Si-LS2 using an optical unit with 18 μm resolution and PCB size 330x250mm(12.99x9.84in.).

