

# Ersa wave soldering systems

In a class of its own!



### Technical Highlights:

- Lowest cost of ownership
- Highest energy efficiency
- Lowest energy consumption
- Highest machine availability
- Extremely service friendly
- Enclosed fluxer with low maintenance
- Free programmable fluxing areas
- Powerful top and bottom heaters
- Individual configuration of the preheat
- Wide choice of solder nozzles for all applications
- Sequential soldering
- Process gas cleaning
- Stable tunnel temperature
- N<sub>2</sub> level independent from the exhaust system
- Flexible conveyor systems to handle all carriers and frames
- Divided conveyor for optimal profiling
- User friendly software
- Ready for traceability



# Ersa wave soldering systems

## In a class of its own!



The electronics manufacturing industry is faced with constantly increasing demands for efficiency and flexibility. At the same time, its customers require highest quality at unbeatable cheap prices. Manufacturers respond to these increasing, and sometimes conflicting, challenges by adapting their manufacturing facilities and strategies. In this tense atmosphere, modern wave soldering systems are an important part of the economic processing of wired components in mass soldering processes.

The many challenges posed by complex electronic assembly units in the processing stage require modern manufacturing systems that are able to flexibly adapt to the most diverse demands. The Ersa POWERFLOW concept allows, for the first time, to implement these different machine concepts into a system.

Thanks to its modular design, Ersa POWERFLOW is available in a variety of configurations, including a high-end full tunnel inert gas soldering system and open atmosphere wave

soldering systems, all of which stand out in terms of availability, cost effectiveness and quality.

### Ersa wave soldering systems include the following systems:

#### POWERFLOW N<sub>2</sub> POWERFLOW e N<sub>2</sub> ETS 330

The POWERFLOW N<sub>2</sub> full tunnel inert gas soldering system represents the maximum expansion stage of this new generation of machines, from which the POWERFLOW e N<sub>2</sub> derives as a partially modular full tunnel system.

The POWERFLOW N<sub>2</sub> comprises several equipment features: fluxer, pre-heating sections and soldering module offer a wide range of configuration options, thanks to which the system can be adapted for special customer requirements. Particularly noteworthy are the pre-heating section and the soldering module. These available options are specifically customised based on the requirements of lead-free soldering

processes and offer a safe base in the production of highly sophisticated and complex assembly units with a high heat capacity.

For manufacturing environments, in which floor space is the main priority, the POWERFLOW e N<sub>2</sub> represents an interesting version. The partially modular design of this series provides all the essential options in a compressed form, which makes the entire system more compact, thus requiring less floor space.

The ETS 330 is a compact wave soldering system for the industrial manufacture of small to medium production volumes. The system is limited in its configuration options and working width, however, it offers easy operation thanks to program controlled processing of the assemblies to be soldered.

Thanks to the safety of very stable processes and repeatable parameters, Ersa's wave soldering systems optimise quality, costs and on-time delivery in the manufacturing process of our customers.



POWERFLOW e N<sub>2</sub>



ETS 330

# Fluxer

## Best process safety, even with high throughput

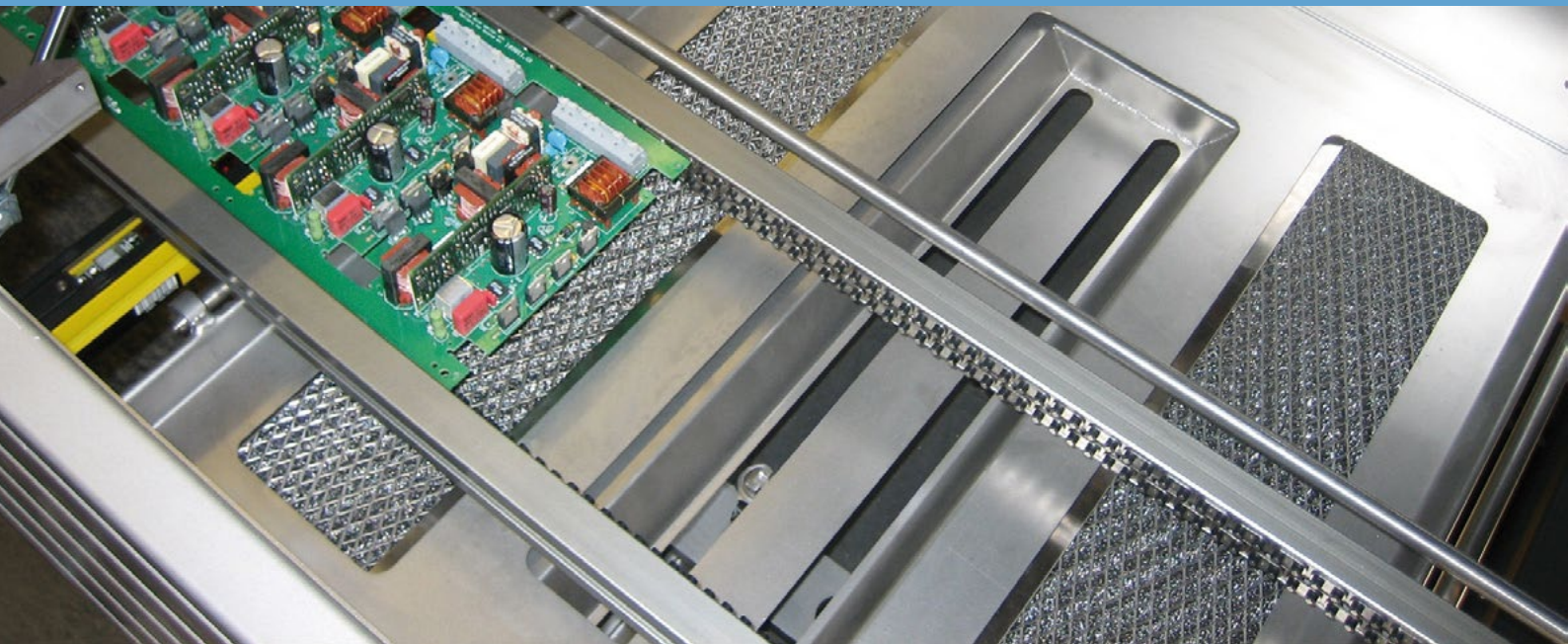

*Fluxer – top view*

Today, spray systems are standard equipment for any wave soldering machine, however they differ significantly in detail. Erska offers many innovative solutions for the fluxer.

Particular attention is paid not only to the safety of systems but also to their cost effectiveness, i.e. flux material consumption and processing speed.

Using high quality materials enables the use of VOC-free flux materials.

Spray sections for specific products can be entered graphically on ER-SASOFT. This highly convenient type of process planning helps to greatly reduce flux material consumption.

If during the production process there is no guarantee that the assembly units are always inserted in the same position into the solder frames, the PCB scanner can automatically detect the outline of the PCB in order to apply the targeted flux material.

### Technical highlights:

- Economical
- Easy to maintain
- 2 spray heads
- Easy to program
- Standard containers up to 25 liters

The spray systems are supplied directly from standard containers. Therefore, the decanting of flux material into solid tanks can be avoided, thus offering maximum safety.

Wave soldering machines also offer appropriate options for the continuous monitoring of flux material levels and flux material consumption.

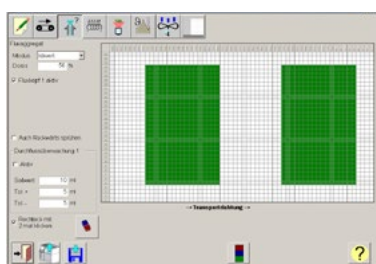

*Entry mask for sequential fluxing*



# Ersa POWERFLUX

## Selective fluxing with high precision

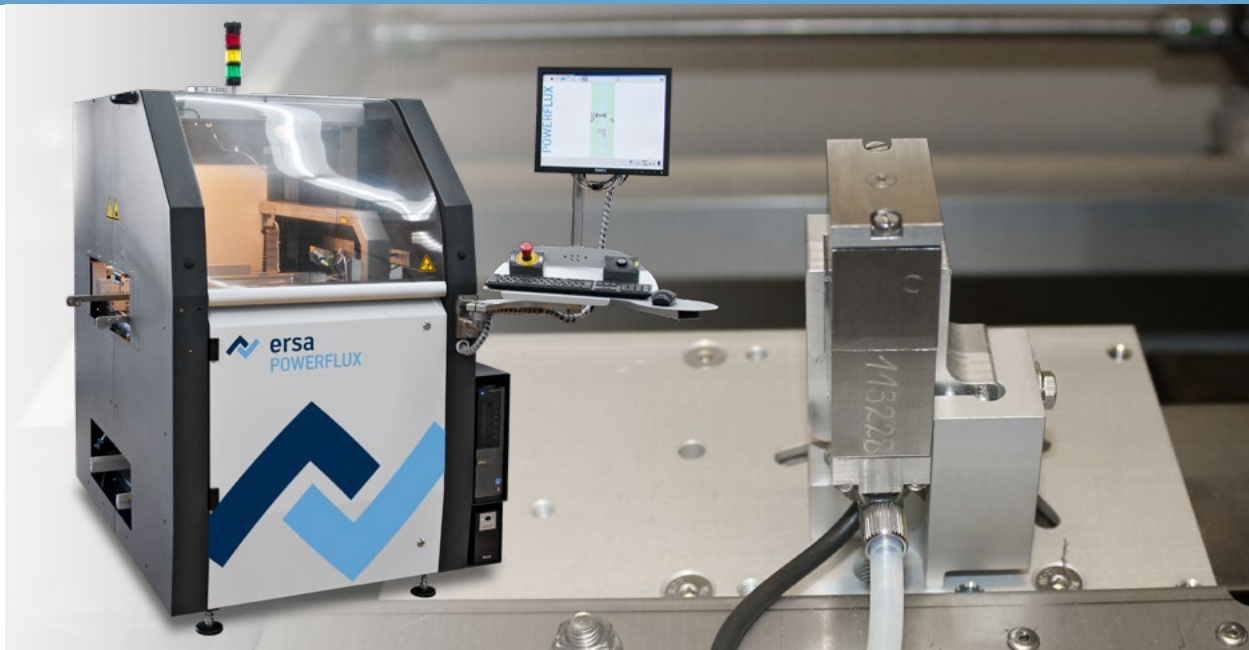

*Selective fluxer for a waste-free flux application*

Ersa POWERFLUX was developed for the fluxing of assembly units, which are transported in solder masks. The solder masks are often used here to cover already reflow soldered SMT components on the wave soldering side. THT components for the wave soldering process can be found in the open sectors of solder masks.

In a conventional wave soldering process, flux material is applied with spray fluxers. These apply the flux material uniformly and smoothly over the entire solder mask and PCB. This conventional flux process offers two huge potentials for improvement. On the one hand, the flux material must not necessarily be applied on the solder mask. On the other hand, the flux material usually crawls into the capillary gap, which automatically forms between the PCB and the solder mask, along the mask openings.

This flux material, which crawls under the mask, can lead to adverse long-term effects on the assembly unit if it comes into contact with flux material residues from the SMT process.

The Ersa POWERFLUX exploits this potential for improvement, since, as with an ink-jet printer, it applies the flux material only to the sections of the assembly unit that are also wave soldered. The solder masks stay dry and the flux material manages not to enter the capillary gap between the assembly unit and the solder mask.

### Technical highlights:

- Lower flux material consumption
- Reduced soiling of solder masks
- Reduced need of cleaning solder masks
- Longer shelf life of solder masks
- No contamination in sectors covered by SMD due to the wave soldering flux material

*Multi-nozzle flux system consisting of 4 spray heads*

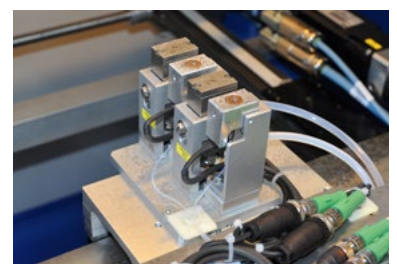

# Pre-heating

flexible, efficient, uniform, stable, repeatable

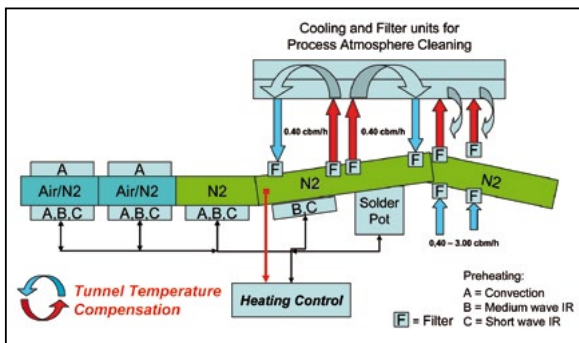

**Functional diagram of the inert gas tunnel of the Ersa POWERFLOW N<sub>2</sub> with atmospheric cleaning and temperature compensation of pre-heating sections**

The pre-heating process plays a key role during lead-free soldering, since a substantial portion of the required soldering heat demand is transmitted here. The pre-heating section of the POWERFLOW makes sure that, under all operating conditions, the pre-heating process runs in a stable way and is repeatable. It also ensures that set temperature profiles and process windows are observed.

Short-wave infrared emitters transfer the different energy amounts almost without inertia.

Thanks to convection modules, which can be arranged below or above PCB conveyors, PCBs can be gently, uniformly and very effectively heated, whereby heat loss and high temperature differences are minimised. Medium-wave emitters also support homogeneous heating of high-mass PCBs.

The speed-controlled blower motors enable the implementation of different heat transfer rates at a constant temperature, which, in turn, is a great advantage in the event of mixed throughput of assembly units.

With the freely configurable pre-heating section, even the greatest demands can be covered.

## Technical highlights:

- Variable in length and combination
- Convection from below and above
- Pyrometer control
- Tunnel temperature compensation

In addition, the POWERFLOW features automatic temperature compensation. The heating of the system tunnel is measured at suitable points and corrects the temperatures of the pre-heater module accordingly with complex algorithms. In this way, constant operating conditions can be ensured despite variable energy output.

Pyrometers for interactive temperature control or for documentation and future traceability of the PCB temperature are also available as an option.

# Conveyor

## flexible concepts for all requirements



Process tunnel

For PCB conveying in the soldering system, options include systems with solder frames and finger conveyors.

The solder frame conveyor is rested on a robust pin chain, which is guided into a profile. Thanks to simple adjustments to the system, solder frames from external manufacturers can also be conveyed. Replacing a third-party make with a wave soldering machine manufactured by Ersä enables existing solder frames to continue to be used, and investing in new solder frames is no longer necessary.

As an option, the frame conveyor system can be separated after pre-heating. In this case, soldering module conveying has a separate drive. Hence, different speeds can be adjusted in the flux, pre-heating and soldering sections.

The finger conveyor system can be used for conveying bare PCBs, as well as masks. A motor-driven centre support can be positioned and controlled by a programme in order to prevent bending of wide PCBs.

Precise PCB tracking allows maximum throughput rates, since PCBs or solder frames are conveyed through the machine almost without separation gaps. Standardised interfaces ensure a smooth transition of PCBs from and to the connected peripheral devices.

### Technical highlights:

- Frame or finger conveyor
- Shared conveyor
- Use of third-party frames
- Sturdy chain instead of conveyor belts
- Low maintenance
- Flexible speeds
- Precision

# Soldering module

## Innovations for demanding lead-free applications



### **POWER-WAVE nozzle**

With regard to soldering modules, POWERFLOW N<sub>2</sub> resorts to the proven Ersa double wave soldering technology, on the basis of which the solder unit has been completely redesigned in order to meet the (increasing) market requirements and needs.

The solder unit is designed to be user-friendly and allows the use of a wide range of different solder nozzles. The combination of solder nozzles can be optimally adapted to user needs.

All relevant parameters of the solder units are continuously monitored, including the temperature of the solder, the solder level in the solder pot, the speed of the solder pump drive, the supply of solder bars in the

automatic soldering supply, as well as residual oxygen content of the inert gas atmosphere in full tunnel systems.

The distance between the solder nozzle and the PCB can be easily adjusted from the outside, without having to open the tunnel. Alternatively, this can also be done automatically through optional actuators, whereby these parameters, as well as all other assembly unit-specific soldering parameters, are stored in the soldering programme used.

### **Technical highlights:**

- Lead-free
- Double soldering module
- Nozzle height adjustment (manual and automatic)
- Easy maintenance: The nozzle shaft can be removed without tools; the support stand is housed in the machine
- Solder nozzle combinations for different applications/Vario Wave
- Exchange solder pot with trolley and heat-up station
- Soldering bar supply with monitoring for all commercially available bar formats
- Sequential soldering
- User-friendly
- Flexible solder nozzle configuration
- Optimal soldering results





**Combination of VARIO-WAVE solder nozzles**

For maintenance work, the solder unit is electrically lowered and positioned out of the machine on a support stand. The support stand is integrated directly into the soldering module and, in order to be used, it only needs to be pulled out from the machine. Accessibility of the solder pot for maintenance or repair work can be easily achieved. For example, solder pump, canal and solder nozzle units can be removed from the solder pot without using tools. In addition, during assembly, no tools or any kind of adjustment work are required.

Naturally, a high-quality protective coating on all parts that come into contact with the solder, providing protection against aggressive substances, is included in all Erska wave soldering systems.

**A new generation of solder nozzles**

The newly developed and patented VARIO-WAVE solder nozzle has been especially adapted and optimised in order to meet the various market requirements. It is suitable as a pre-solder wave and/or final solder wave and offers a variable wetting length of 35 or 65 mm.

The use of two nozzles in a double wave solder unit allows a variable wetting length of 35/65/100/135 mm. Thanks to the combination of the flexible wetting lengths with a high flow speed of the solder, this solder nozzle is also suitable for the assembly units of power electronics with high heat capacity, as well as for assembly units with low energy consumption

**Other advantages include:**

- Optimal wetting characteristics for critical SMD layouts on the soldering side
- Particularly suitable for selective solder masks with different structure height on the soldering side, where a pressure compensation takes place due to the construction design of the solder nozzle.
- Reduced risk of tearing thanks to optimal flow characteristics
- Consistent positive feedback from customers
- Compatible with older Erska soldering systems
- Suitable for leaded/unleaded double soldering modules, since the functions of pre solder waves and main solder waves are summarised in a solder nozzle

# Software

## Intuitive and easy to operate

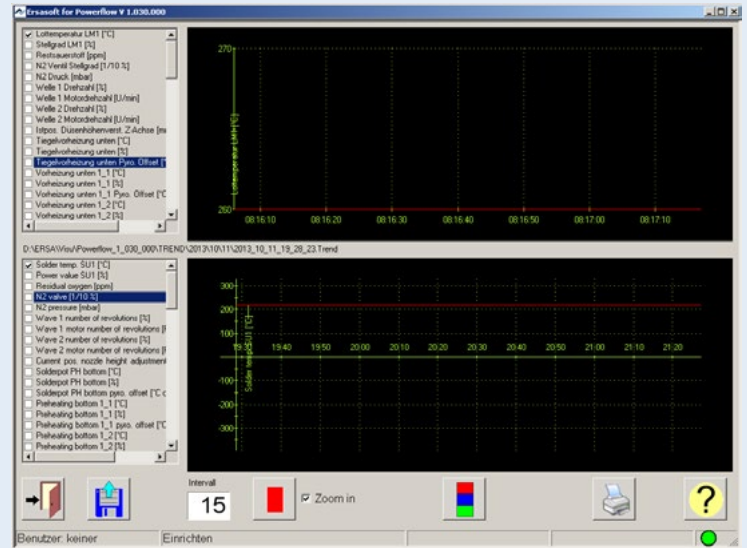
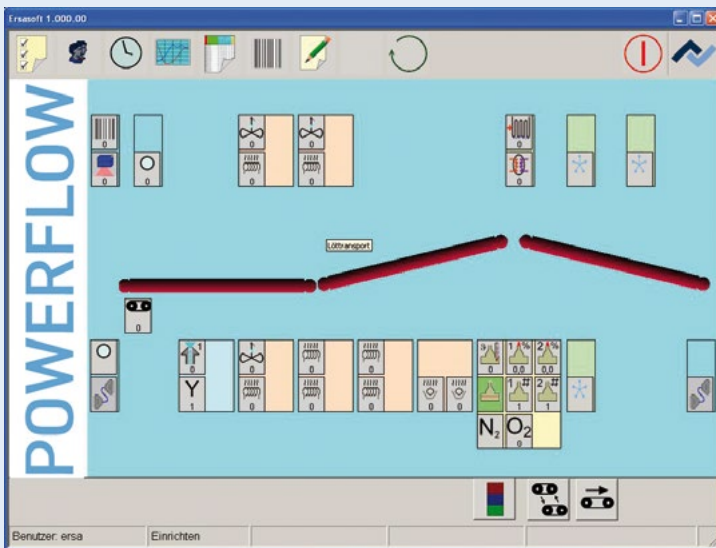

POWERFLOW wave soldering machines are operated via PC control with ERSASOFT. This machine visualisation software offers an extensive range of functions, which support the user during intuitive operation of the machine.

For software interface configuration, all control elements were tailored in order to provide comfortable touch operation. Colour-highlighted and uniformly structured dialogue boxes allow quick orientation and clear separation of input screens, also offering optimal clarity. In this way, the structured design of the software supports intuitive, and therefore easy to learn, machine operation. Moreover, task-related allocation of user rights prevents incorrect machine operation.

For safe machine operation, ERSASOFT displays only the data that matches the actual configuration of the machine. Anyone who has already worked with Ersma Reflow or selective soldering systems can quickly recognise the similar software structure. At the same time, staff training is less required.

The process recorder, which continuously records the actual values of all relevant units for the soldering process, or the soldering report, which stores process data with all necessary traceability information, are standard and owned by ERSASOFT. Similarly, comprehensive alert management is included in the scope of delivery. All arising messages are saved with a time stamp and user ID. This data is available as ASCII data and can therefore be more easily further processed by higher-level systems.

### Highlights:

- Soldering report, process recorder, alert management (in the scope of delivery)
- Clear and intuitive operation
- Comfortable touch operation
- Downward compatibility

Please note that ERSASOFT is fully backward compatible within a machine generation. In this way, the customer can also take part in innovative software features developed only after the machine is purchased.

# Ready for Traceability

## Tracing interface for transparent production processes

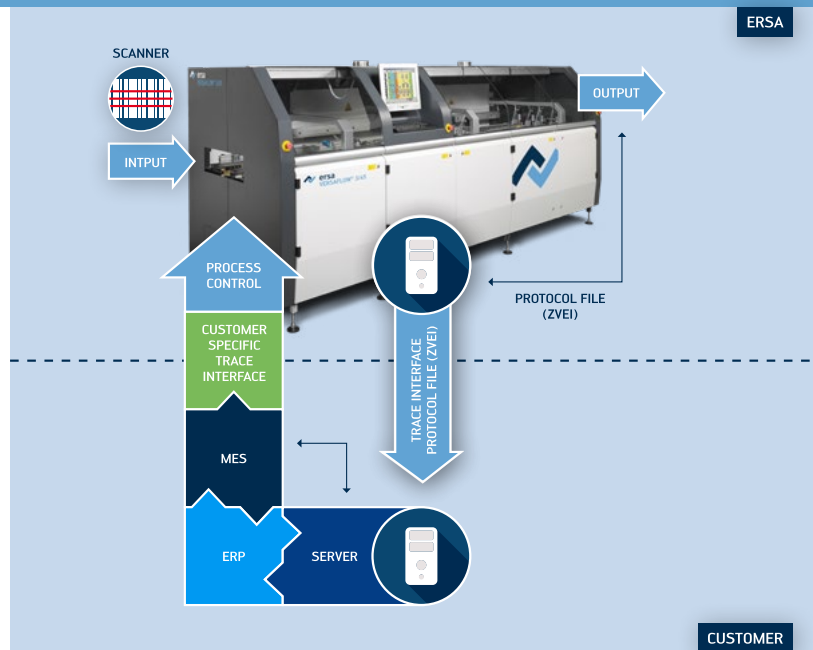

The XML structure of the report file in accordance with the ZVEI standard includes:

Unique ID of processed materials  
e.g.: Barcode, matrix code  
> unitname  
Machine or workstation  
> equipment  
Processing time  
> starttime, endtime  
State of processing,  
e.g.: ok or nok > state

In addition, as an option, the following values are recorded:

Parameters and reference values  
> processing parameters  
Measurement data > measuring  
Library name  
Soldering programme name

### Traceability

The high quality requirements in the electronics manufacturing industry increase the demand for secure product traceability for OEM and EMS companies. For each assembly unit, the exact origin, time of production and manufacturing conditions must be identifiable. Thanks to clear identification, the origin of an end product can be traced back to the individual component throughout the entire supply chain. As a result, errors and their causes can be quickly and safely identified in the event of recall. In this way, any expenses and financial loss for such measures can be strongly reduced.

Ersa has taken up this challenge and, as an option, it has equipped the machines of the POWERFLOW N<sub>2</sub> series with a data interface that complies

with the ZVEI standard. All important process parameters are hereby offered in a higher-level system in an XML structure.

In this way,

- documentation is provided on when and with which process conditions a specific assembly unit was soldered.
- an analysis of process values (process monitoring), concerning permitted limit values, is possible.
- individual serial numbers can be assigned to process data (process tracing).

Traceability and quality assurance of the finished products is therefore guaranteed. Moreover, the Ersa POWERFLOW N<sub>2</sub> can be integrated into the process control of a Manufacturing Execution System (MES). Such systems approve the process

only after checking the plausibility of order data with the wave soldering machine.

Process locking ensures that

- faulty products will not be further produced.
- wrong products are identified and discharged.
- the process sequence is maintained.

A specially developed interface enables coupling with almost all MES available on the market.

# Ersa POWERFLOW N<sub>2</sub>

## The solution for demanding jobs



### Technical highlights:

- Extremely high throughput rates
- Process gas purification
- Sequential soldering
- Motor-driven spray head axis
- Comprehensive software features
- Spray area programming
- Automatic spray area acquisition

POWERFLOW is a carrier of technology in the field of wave soldering systems. The system stands out for its wide range of options and can be individually adapted to the most diverse requirements.

The fluxer can be equipped with two independent flux material supply systems. Suction above and below the assembly unit, as well as a separate conveyor system, ensure maximum cleanliness for the process tunnel. For maintenance works, the entire spraying unit can be extended out of the machine.

The length of the pre-heating sections enables the manufacturing of assembly units with high mass while maintaining a high throughput. Medium and short wave infrared emitters and convection heating are available as heating modules.

For the solder unit, which is very easy to maintain, different solder nozzle combinations are also available. Wetting times and solder wave heights are very flexible and allow high clearance in order to optimise soldering parameters individually for each assembly unit. If different solder alloys are used in current manufacturing, different solutions can be provided. Conveyor systems are available for solder frames or directly for transport of PCBs on finger conveyors.

The process tunnel features process gas purification, which constantly filters out arising impurities. As an option, the residual oxygen content of the inert gas atmosphere is monitored and/or controlled.

System control is carried out via PC thanks to a touch screen monitor. The visualised Ersasoft control

software controls and monitors the entire system. The convenient user interface enables effective, rapid and safe use of the soldering system for the user.

A process recorder works in the background, continuously recording all the relevant data of the soldering system. At the same time, data relevant for manufacturing can be made available on a trace interface for higher-level MES networks. In the opposite direction, a locking process can occur. After a sanity check of order data, the process is approved.

# Ersa POWERFLOW e N<sub>2</sub>

## The compact solution



### Technical highlights:

- Low investment volumes
- Convenient floor space
- Modern control concept
- Extractable fluxer module
- Full nitrogen tunnel
- Different preheating systems available
- Finger or frame conveyor

The POWERFLOW e N<sub>2</sub> creates the basis for a cost effective soldering system platform. Its equipment options can be compared to the POWERFLOW, however, with limited availability and functionality. As a result, investment costs for these soldering systems are lower and less floor space is required compared to the POWERFLOW.

The pneumatically-driven flexible and programmable spray fluxer is equipped with a spray head and supplied with flux material from the original container.

With regard to pre-heating, the POWERFLOW e N<sub>2</sub> offers the option to extend process length. Options include medium or short wave infrared emitters or compressed air convection modules. Similarly, convection heaters can be installed above the conveyor system in the system tunnel.

The soldering module is designed as a double wave unit and offers, without limitation, the opportunity to use the wide range of proven Ersa solder nozzles. The parameters of the soldering module, which are relevant for manufacturing, are continuously monitored by the system control.

As a conveyor system, solder frames or finger conveyor systems are also available.

The POWERFLOW e N<sub>2</sub> is operated via a 5.7" touch panel or via PC. The optional machine PC offers an extensive range of functions for the user, such as a display for the process recorder and the soldering report.

The software is neatly designed and allows intuitive and safe handling of the machine for the user. The control system offers the opportunity to store up

to 99 soldering programmes, which can be activated manually or via a coding on the solder frames. A weekly time switch ensures operational readiness in time for the start of a shift. The control system continuously monitors all relevant unit states and shows their actual values and operating conditions on the operating panel.

All these features ensure a safe, stable and repeatable soldering process.

# Ersa ETS 330

## The solution for small and medium-size series

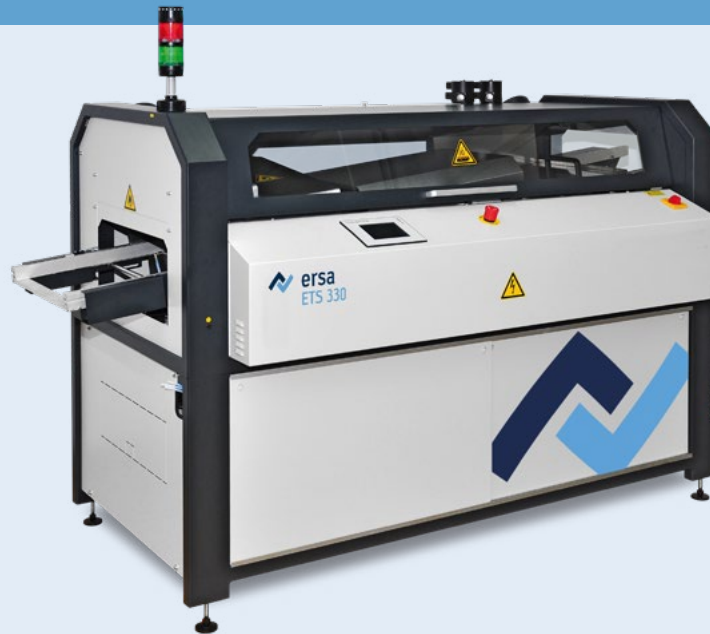

Due to its low investment and operating costs, the compact ETS 330 wave soldering machine offers best preconditions to manufacture even small production lots in a professional and cost-effective way. Investing less money does not mean compromising the soldering process. For assembly unit conveying, the machines use the Ersa standard solder pallets.

The fluxer is designed as a spray flux system and, in order to ensure repeatable processes, pre-heating offers temperature control and a programmable holding time of assembly units. In this way, despite construction-related short pre-heating, longer heating time is allowed.

The soldering module contains an enamelled steel solder pot, which, as an option, can be equipped with a second wave shaper.

The ETS 330 is operated via a 5.7" touch panel. The clear visualisation structure ensures intuitive and safe operation, making it easy to handle for all employees. The software can manage 199 soldering programmes and offers a weekly time switch and a solder frame counter. All unit conditions are clearly shown and the actual values of temperatures and speeds are displayed as plain text. Continuous monitoring of the machine and the recording of all necessary operating data ensure a safe and repeatable soldering process.

The conveyor system of the ETS 330 can process solder pallets with a width of 330 mm. The ETS 330 is designed for manual feeding, whereas the system can alternatively also be integrated in a conveyor system and thus be operated inline.

### Technical highlights:

- Frame conveyor system
- Temperature-controlled pre-heating
- Double wave soldering module
- In-line chaining
- Modern control system with touch operator interface including weekly time switch & management of 199 soldering programmes

Thanks to a small investment, the ETS 330 allows a payback of initial costs in the shortest possible time, even in the event of low proceeds of the products to be manufactured.

# Ersa Services

## Our global commitment for your success



*Customers and interested parties are pleased to use Ersa application centres in order to perform test solderings or to test the efficiency of systems*

Around the world, our customers and business partners have access to spacious demonstration, application and training centers outfitted with the most modern equipment. There are eight Ersa Service Centers of this kind in total, all of them boasting the complete soldering systems product portfolio, as well as the Ersa "Tools, Rework and Inspection" business line.

Regardless of the Ersa Service Center you choose: Our experienced application engineers are glad to welcome you in all of them, ready to demonstrate the Ersa hardware and test it for specific purposes. The chance to really prove our mettle comes for Ersa when, in cooperation with you, we are allowed to optimize your subassembly under exactly defined conditions!

Additional modern training and conference facilities in the immediate vicinity permit an intensive exchange of experience and transfer of know-how. Both facilities, the demo centers and the conference rooms are used for the Ersa Know-How Seminars or Technology Days, tailored specifically to customer requirements.

The Ersa Service Team is already looking forward to welcoming you to our application center – whether for testing, training, Technology Days or for the Know-How Seminar. You will find an Ersa Service Center within striking distance!

*Ersa is particularly renowned for providing know-how in the form of staff training and seminars*

# Electronics Production Equipment Presence in 135 countries

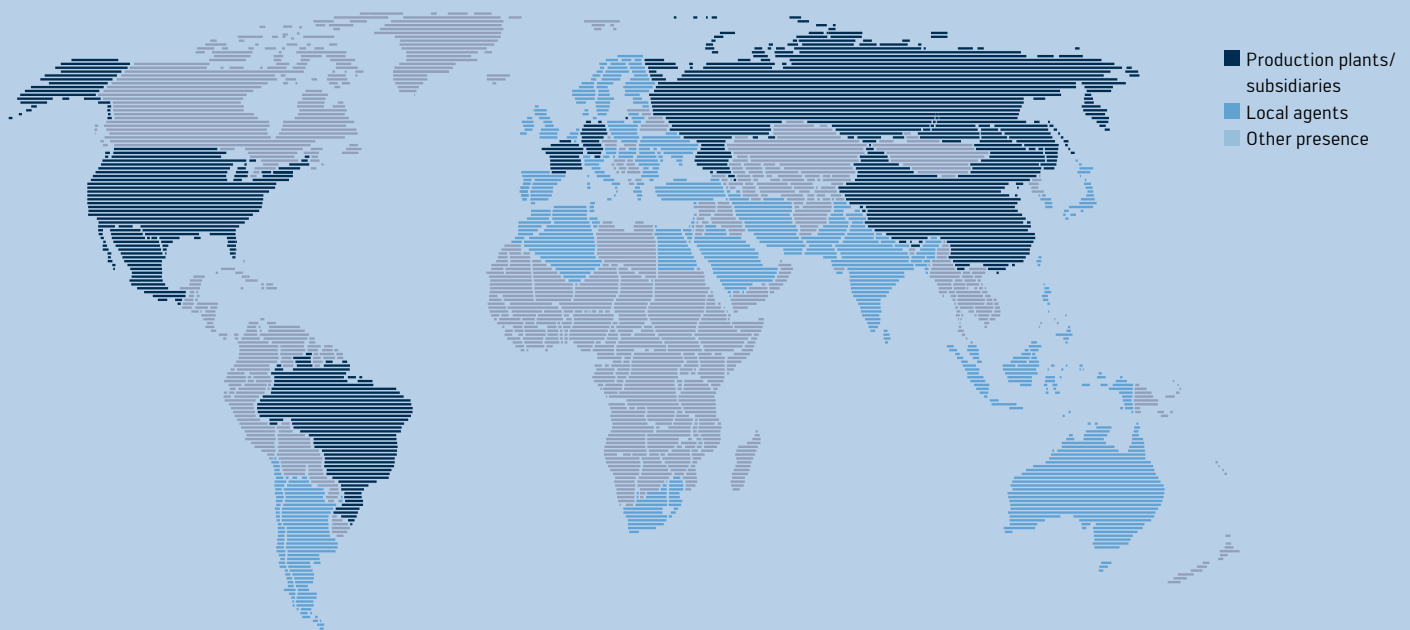

## America

Ersa North America  
1779 Pilgrim Road  
Plymouth, WI 53073  
USA  
Phone +1 920 893 3772  
from the US: 800 363 3772  
Fax +1 920 893 3322  
info-ena@kurtzera.com  
www.ersa.com

## Mexico

Kurtz Erska México, S.A. de C.V.  
Av. Lopez Mateos Sur Núm. 1450 Int. 7  
Col. Las Amapas (Plaza las Villas)  
Tlajomulco de Zúñiga/Guadalajara  
Jalisco C.P. 45643  
Phone +52 33 15 93 18 63  
info-kmx@kurtzera.com  
www.ersa.com

## Asia

Kurtz Erska Asia Ltd.  
Unit 03-05, 8th Floor  
One Island South  
No. 2 Heung Yip Road  
Wong Chuk Hang  
Hong Kong  
China  
Phone +852 2331 2232  
Fax: +852 2758 7749  
info-eap@kurtzera.com  
www.ersa.com

## China

Ersa Shanghai  
Room 720, Tian Xiang Building  
No. 1068 Mao Tai Rd.,  
Shanghai 200336  
China  
Phone +86 213126 0818  
Fax +86 215239 2001  
info-eap@kurtzera.com  
www.ersa.com

## France

Ersa France  
Division de  
Kurtz France S.A.R.L.  
15 rue de la Sucharde  
21800 Chevigny Saint Sauveur  
France  
Phone +33 38056 6610  
Fax +33 38056 6616  
info-efr@kurtzera.com  
www.ersa.com

Kurtz Holding GmbH & Co.  
Beteiligungs KG  
Frankenstr. 2  
97892 Kreuzwertheim  
Germany  
Phone +49 9342 807-0  
Fax +49 9342 807-404  
info@kurtzera.de  
www.kurtzera.com

Ersa GmbH  
Leonhard-Karl-Str. 24  
97877 Wertheim/Germany

Phone +49 9342 800-0  
Fax +49 9342 800-127  
info@ersa.de  
www.ersa.com

