



WPCL IUT3

Water recycler: SYMBIO-unit for processing heavy metal containing rinsing water in a CrossLoop configuration.

For the factory-made modular integration in **kolb** AQUBE® X cleaning systems with integrated ClosedLoop technology.

Additional depth of the cleaning system: ca. 400 - 700 mm

Part number: 0905_ _ _ _ _ WPCLIUT3



Certifications:

This system in its basic version was certified for its energy and water saving processing, for easy operability and for the standard integration of comprehensive safety features.

- Cost-effective water treatment for **kolb** three-tank systems
- SYMBIO-integration as a framework module at the system back
- Fully enclosed solidly integrated unit
- CrossLoop technology for significant reduction of fresh water use and for waste water disposal
- Recycling and multiple use of clear rinse water in DI / DM quality
- 6 filter stages
- Fully automated process
- Process and service intervals PLC controlled, monitored and displayed
- Integrated water exchange / refilling system
- Also ideally suited for retrofitting **kolb** PSB600 systems (from year of construction 2016)

Key applications



AQUBE XV9



AQUBE XV7



AQUBE XH9



AQUBE XH7

Systems for product cleaning (PCBs, DCBs, HDIs etc.) and tools cleaning (screens, stencils, solder frames / carriers, filters etc.) have to exchange the water after every single rinsing process or are equipped with an integrated rinsing water filtering cycle, which already allows multiple use of the rinse water. The water-saving cleaning systems from **kolb** have already integrated such a ClosedLoop recycling technology as a standard feature, which already allows a repeated use of the rinse water. The CrossLoop technology of WPCL IUT3 extends these resource savings of water again by a multiple.

WPCL IUT3 SYMBIO-modules with CrossLoop crossover recirculation technology and sixfold filtration manage the recycling of wastewater, thus significantly reducing the need for fresh water and the cost for producing DI water as well as for the disposal of contaminated used up water.

The installation of the fully enclosed compact WPCL IUT3 SYMBIO-module is on the rear side of the cleaning system and increases its depth by only about 400 - 700 millimeters.



WPCL IUT3

Water recycler: SYMBIO-unit for processing heavy metal containing rinsing water in a CrossLoop configuration.

Part number: 0905_ _ _ _ WPCLIUT3



Function

In a cleaning system, the rinse water usually shows three different process states:

1. Polluted water, which is no longer suitable for rinsing and has to be either treated for reuse or has to be discharged into the local sewage network.
2. Water that has been used for rinsing, but still is usable for this process because it is filtered in a closed loop inside the cleaning system and thus can be reused several times.
3. Fresh water or fresh recycled water which the system collects during the rinsing water exchange process either from the local water connection or from a reprocessing plant.

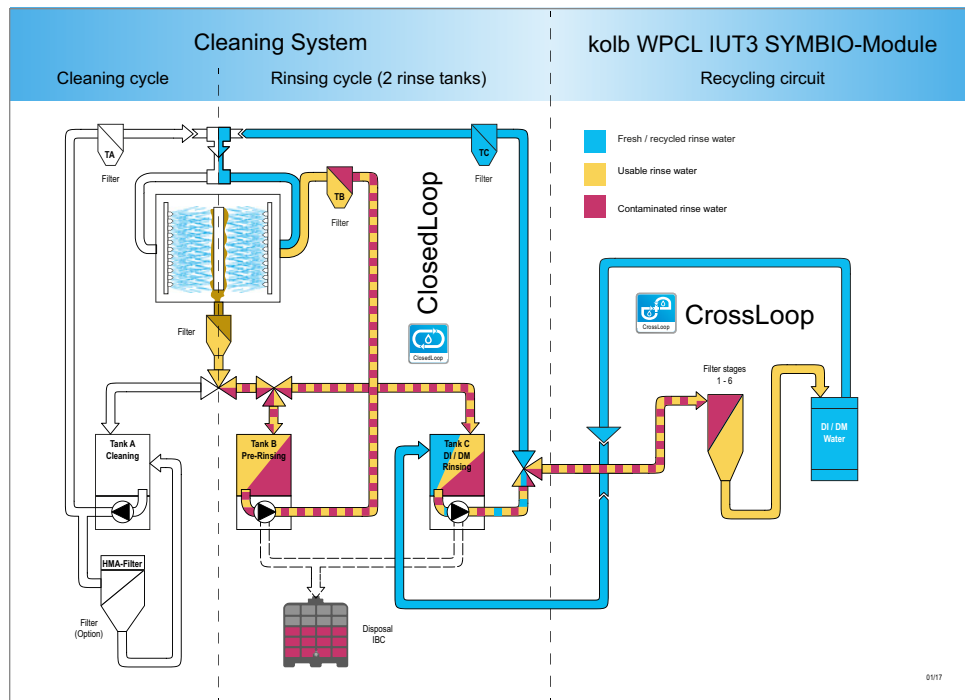

Prerequisite for cost-effective water recycling is a three-tank cleaning system. With the integration of the WPCL IUT3 SYMBIO module, the system receives a recycling function for the rinse cycle (for tank C).

Pre-rinse cycle: After the pre-rinse process (normally with tap water), the system stores the rinse water back into tank B for multiple use.

Clear rinse cycle: The clear rinsing process in the cleaning system is now carried out from tank C filled with DI / DM water. During the process and subsequently, the used rinse water from Tank C is bypassed into the SYMBIO module. There, over 6 filter stages, organic and heavy metals (for example, lead, tin, silver, copper) are absorbed until the water corresponds again to the μS conductance preset in the PLC of the system. The refreshed water is then returned to tank C and stored there for the next rinse cycle.

Disposal / filter change: If the rinse water from one or both circuits no longer meets the (SPS-controlled) quality specifications of the operator, the system automatically changes the tank contents. The contaminated water is automatically pumped, e.g. into an IBC container, for subsequent disposal by a specialist company. The filters 1 - 3 are replaced, the adsorber filter cartridges 4 - 6 are regenerated and the tanks are filled with fresh water so that all functions of the SYMBIO-unit are available to the next rinsing processes.