

8 7 6 5 4 3 2 1

REVS				
REV.	DESCRIPTION	DATE	GS#	APPROVED

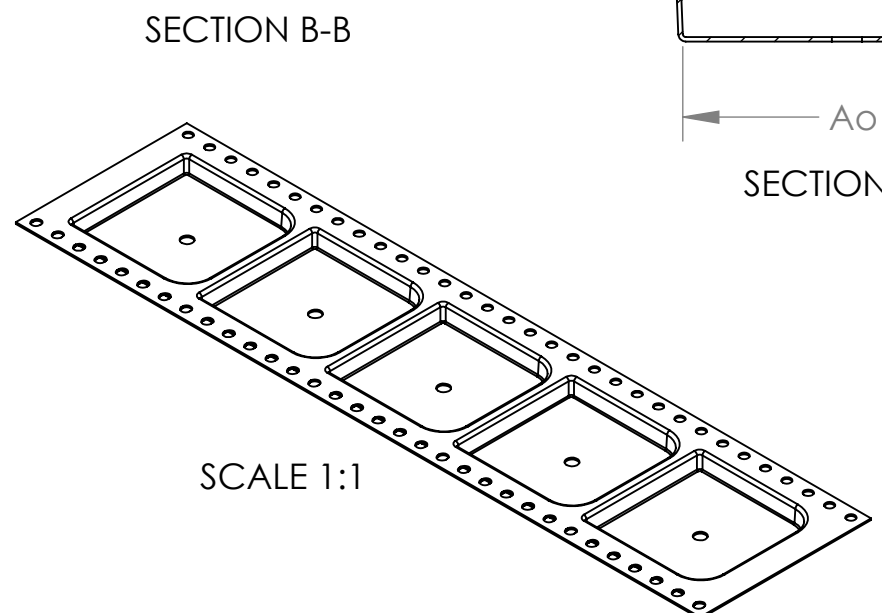
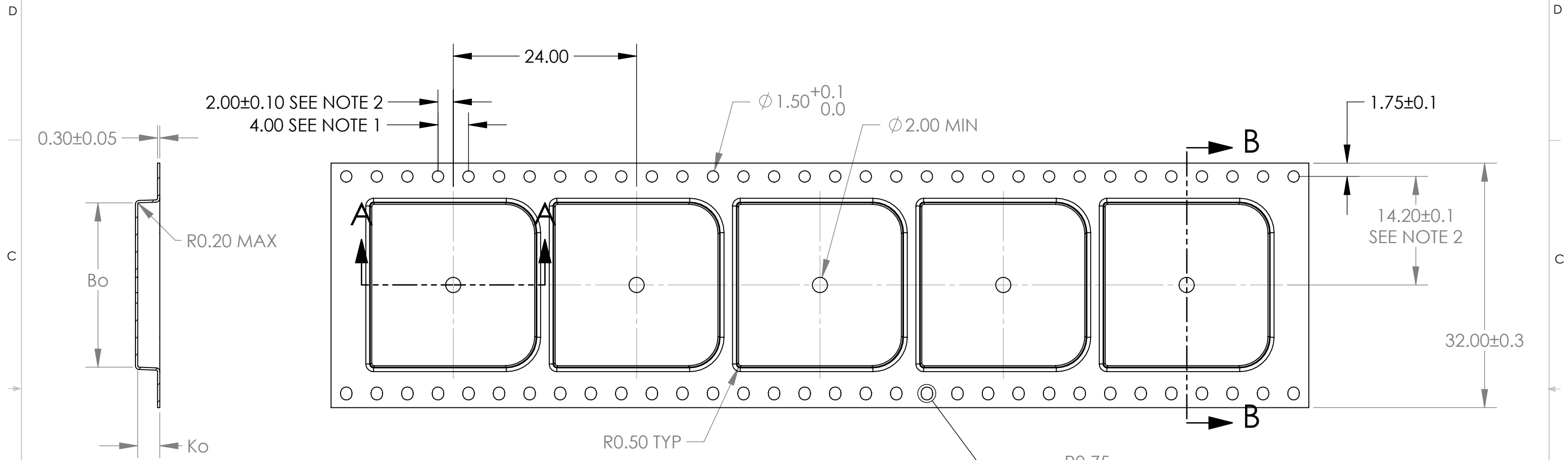

	DIM	±
Ao	21.70	0.1
Bo	21.50	0.1
Ko	2.90	0.1

THE INFORMATION CONTAINED IN THIS DRAWING IS THE SOLE PROPERTY OF ADVANTEK INC. ANY REPRODUCTION IN PART OR WHOLE WITHOUT THE WRITTEN PERMISSION OF ADVANTEK INC. IS PROHIBITED.



TITLE: ADVANTEK PART DRAWING NUMBER EGA041-A  
CARRIER TAPE

TOLERANCES UNLESS - SPECIFIED 1 PL ± 0.2 2 PL ± 0.10	MATERIAL PS+C	APPROVED BY: BTH	
CAD GENERATED DRAWING, DO NOT MANUALLY UPDATE DO NOT SCALE DRAWING	DRAWN BY: MME	DATE 2019-04-12	SCALE 2:1 SHEET 1 OF 1 SIZE B
	PROJECT # 23805.02	DRAWING # T116771BT	REV. 0

- NOTES:
- 10 SPROCKET HOLE PITCH CUMULATIVE TOLERANCE ±0.2
  - POCKET POSITION RELATIVE TO SPROCKET HOLE MEASURED AS TRUE POSITION OF POCKET, NOT POCKET HOLE.
  - Ao AND Bo ARE MEASURED ON A PLANE AT A DISTANCE "R" ABOVE THE BOTTOM OF THE POCKET.

8 7 6 5 4 3 2 1